

# IoT Based Agriculture Pumping System and Monitoring

Sachin P. Nalawade<sup>1</sup>, Dnyaneshwar S. Karche<sup>2</sup>, Darpan S. Talekar<sup>3</sup>,  
Samiur Rahman<sup>4</sup>, Pratik S. Walhekar<sup>5</sup>

<sup>1</sup>Ass. Professor, Department of Electrical, Navsahyadri Group of Institutions, Pune, Maharashtra, India,  
Savitribai Phule Pune University, Pune

<sup>2,3,4,5</sup>Students, Department of Electrical Engineering, Navsahyadri Group of Institutions, Pune, Maharashtra, India,  
Savitribai Phule Pune University, Pune

---

## ABSTRACT

Efficient utilization of water resources and environmental monitoring are critical requirements in modern agriculture. This paper presents the design and implementation of a solar-powered IoT based smart agriculture system capable of automatic irrigation and environmental regulation. The proposed system employs a soil moisture sensor to assess soil conditions and a DHT11 sensor to monitor ambient temperature and humidity. Sensor data is processed by a microcontroller based control unit which executes predefined decision logic to regulate a water pump and cooling fan via a relay module. The integration of a solar energy source enhances system sustainability and enables deployment in remote agricultural locations with limited power availability. A Wi-Fi module facilitates remote monitoring, while an LCD display provides real-time local feedback. Experimental evaluation of the developed prototype demonstrates reliable automation, optimized water usage, and effective environmental control. The proposed system offers a practical, energy-efficient, and cost-effective solution for precision agriculture applications.

**Keywords:** IoT, Smart Irrigation, Solar Energy, Soil Moisture Sensor, DHT11, Precision Agriculture.

---

## INTRODUCTION

Agriculture is one of the most important sectors for economic growth and food production. Efficient management of resources such as water and energy has become a major challenge in modern agriculture. Factors like water scarcity, changing environmental conditions, and high energy consumption often affect agricultural productivity. Traditional irrigation methods mainly depend on manual operation, which can lead to excessive water usage, increased labor, and inefficient crop management. To overcome these limitations, automated irrigation systems have been developed. The use of sensors allows real-time monitoring of soil and environmental conditions, enabling better control of irrigation processes. With the advancement of Internet of Things (IoT) technology, agricultural systems can now support remote monitoring and improved decision making. Environmental parameters such as temperature and humidity play a significant role in crop growth. However, many existing irrigation systems primarily focus on soil moisture monitoring and do not provide integrated environmental regulation. In addition, energy consumption remains a critical concern, particularly in remote agricultural areas where conventional power sources may be limited. Solar energy provides a sustainable and energy efficient solution for such applications. The integration of IoT technology, sensor-based monitoring, automation, and renewable energy can significantly improve agricultural efficiency and resource utilization.

This paper presents the design and implementation of a solar-powered IoT-based smart agriculture system. The proposed system performs real-time monitoring of soil moisture, temperature, and humidity, and automatically controls irrigation and environmental regulation mechanisms. The system aims to improve water efficiency, reduce manual intervention, enhance energy efficiency, and support sustainable agricultural practices.

## LITERATURE REVIEW

In recent years, smart agriculture systems have gained significant attention due to the increasing need for efficient water management and environmental monitoring. Traditional irrigation methods often lead to water wastage because they rely on manual operation and lack real-time monitoring. To overcome these limitations, researchers have developed automated irrigation systems using sensor technology.

Earlier studies mainly focused on soil moisture-based irrigation systems. In these systems, soil moisture sensors are used to measure the water content in the soil, and irrigation is controlled based on sensor readings. Such systems have shown improvements in water conservation and irrigation efficiency.

With the development of Internet of Things (IoT) technology, irrigation systems have become more advanced. IoT-based systems allow real-time monitoring and remote access to agricultural parameters. These systems enable users to monitor field conditions without being physically present, improving convenience and operational efficiency.

Researchers have also recognized the importance of environmental factors such as temperature and humidity in agricultural applications. Several studies have incorporated temperature-humidity sensors to monitor environmental conditions. However, many existing systems focus mainly on monitoring rather than automatic environmental control. Additionally, renewable energy sources, particularly solar energy, have been widely explored for agricultural applications. Solar-powered systems provide an energy-efficient and sustainable solution, especially in remote areas where conventional power supply may be limited.

Despite these advancements, many existing systems address only specific aspects such as irrigation control, environmental monitoring, or energy efficiency. There is a need for an integrated system that combines soil moisture monitoring, environmental sensing, automated device control, IoT-based remote monitoring, and renewable energy utilization. The proposed system aims to address these requirements by developing a solar-powered IoT-based smart agriculture system.

### METHODOLOGY

The proposed smart agriculture system is designed using a modular architecture comprising sensing, control, actuation, communication, and power units. The system utilizes the ATmega328P microcontroller as the central processing unit responsible for data acquisition, decision-making, and device control.

The sensing unit consists of a soil moisture sensor and a DHT11 temperature-humidity sensor. The soil moisture sensor continuously measures the volumetric water content of the soil, while the DHT11 sensor monitors ambient environmental conditions. The sensor outputs are interfaced with the microcontroller through appropriate input channels. The ATmega328P periodically samples the sensor data and processes the acquired parameters.

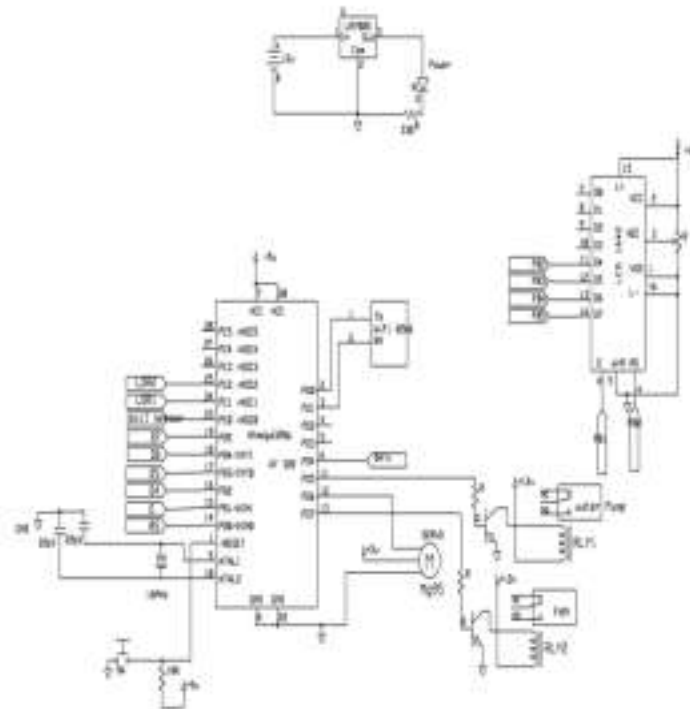
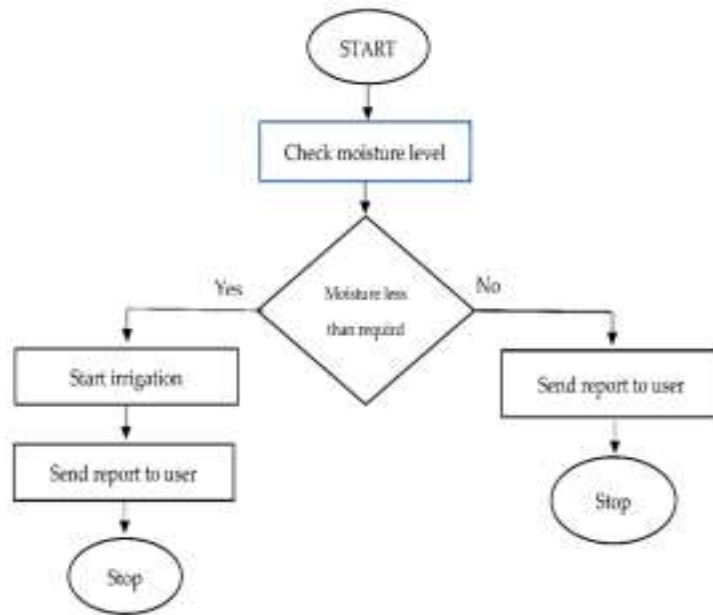

**Fig: circuit diagram**

A predefined threshold-based decision algorithm is implemented within the microcontroller to automate system operation. When the soil moisture level falls below a specified threshold, the microcontroller activates the irrigation pump via a relay module. Conversely, when adequate soil moisture is detected, the pump is deactivated. Similarly, temperature readings obtained from the DHT11 sensor are utilized to regulate environmental conditions. The cooling fan is automatically controlled based on preset temperature limits.

For remote monitoring, a Wi-Fi communication module is integrated with the microcontroller. The module facilitates wireless transmission of sensor data, enabling users to observe environmental parameters and system operation remotely.

To enhance energy efficiency and sustainability, the system is powered using a solar energy source. The renewable power integration ensures reliable operation in remote agricultural environments where conventional power availability may be limited.



**Flow chart**

To enhance energy efficiency and sustainability, the system is powered using a solar energy source. The renewable power integration ensures reliable operation in remote agricultural environments where conventional power availability may be limited.

The overall methodology enables continuous environmental monitoring, automated irrigation control, and intelligent resource utilization.

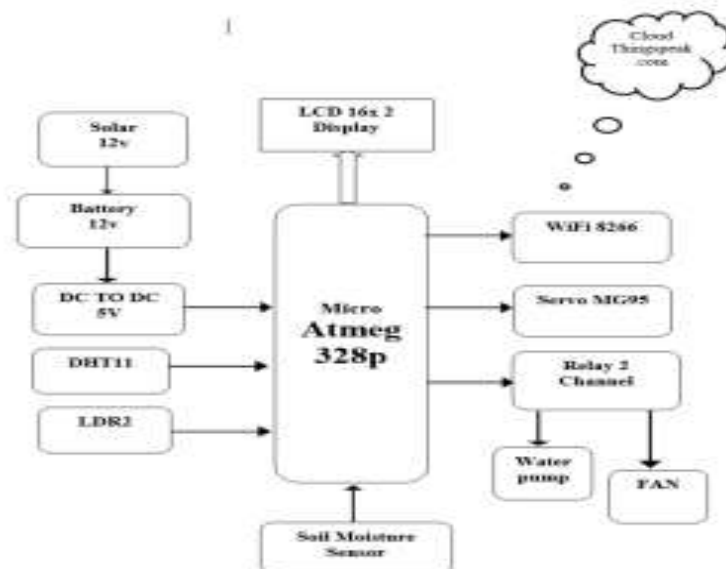

Sr. No.	Component	Function
1.	<b>Microcontroller (NodeMCU / Arduino UNO)</b>	Acts as the main control unit of the system. It reads data from sensors, processes it, and controls the pump accordingly. NodeMCU is preferred for its built-in Wi-Fi capability.
2.	<b>Soil Moisture Sensor</b>	Measures the moisture content of the soil. It helps determine when irrigation is required.
3.	<b>DHT11 / DHT22 Sensor</b>	Measures temperature and humidity of the surrounding environment to monitor field conditions.
4.	<b>Water Pump (DC or AC Pump)</b>	Used for irrigation. It is automatically switched ON/OFF based on soil moisture readings.
5.	<b>Relay Module</b>	Acts as a switch between the microcontroller and the water pump. It isolates the low-power control circuit from the high power pump circuit
6.	<b>Power Supply (5V/12V Adapter)</b>	Provides the required power to the microcontroller, sensors, and pump.
7.	<b>Wi-Fi Module (if Arduino used)</b>	Provides internet connectivity for sending data to the IoT platform. In NodeMCU, this is inbuilt (ESP8266).
8.	<b>LCD Display (16x2)</b>	Displays real-time values of soil moisture, temperature, humidity, and pump status.
9.	<b>Connecting Wires and Breadboard</b>	Used to make electrical connections between the components

## Components

### RESULT AND DISCUSSION

The proposed solar-powered IoT-based smart agriculture system was tested under different soil and environmental conditions to evaluate its performance. The soil moisture sensor successfully detected variations in soil water content, allowing the system to control irrigation automatically. When the soil moisture level dropped below the predefined threshold value, the microcontroller activated the water pump through the relay module. Once the soil moisture level reached the required limit, the pump was automatically turned off. This operation helped prevent over irrigation and ensured efficient water usage.

The DHT11 sensor effectively monitored temperature and humidity conditions. The temperature-based control mechanism operated as expected, where the cooling fan was activated when the temperature exceeded the specified threshold value. The fan was deactivated when the temperature returned to normal conditions. This functionality supports maintaining suitable environmental conditions.

The relay module provided stable switching performance and ensured safe control of the pump and fan. The LCD display accurately showed real-time sensor readings and device status, enabling easy local monitoring. The Wi-Fi module enabled successful wireless transmission of sensor data, allowing remote observation of system parameters.

The solar-powered operation ensured continuous system functionality and demonstrated the suitability of the system for remote agricultural applications. The experimental observations indicate that the proposed system provides reliable automation, efficient water management, and improved environmental adaptability.

This paper presented the design and implementation of a solar-powered IoT-based smart agriculture system for automated irrigation and environmental monitoring. The proposed system uses a soil moisture sensor and a DHT11

sensor to monitor soil and environmental conditions in real time. The ATmega328P microcontroller processes the sensor data and automatically controls the water pump and cooling fan based on predefined threshold values. The system demonstrated reliable performance during experimental evaluation. The automated irrigation mechanism effectively responded to soil moisture variations, helping to reduce unnecessary water usage. The temperature-based fan control provided improved environmental regulation. The integration of solar power enhanced the energy efficiency and sustainability of the system, making it suitable for remote agricultural applications. The Wi-Fi module enabled remote monitoring, improving system accessibility and convenience.

Overall, the proposed system provides a practical, energy-efficient, and cost-effective solution for smart agriculture. The combination of sensing, automation, IoT connectivity, and renewable energy contributes to improved water management and reduced manual intervention.

### **CONCLUSION**

This paper presented the design and implementation of a solar-powered IoT-based smart agriculture system for automated irrigation and environmental monitoring. The proposed system integrates soil moisture sensing and temperature-humidity monitoring using appropriate sensors, with the ATmega328P microcontroller serving as the central control unit. A threshold-based control strategy was implemented to enable automatic regulation of the irrigation pump and cooling fan, thereby improving resource utilization and reducing manual intervention. The experimental evaluation of the developed system demonstrated reliable performance under varying soil and environmental conditions. The automated irrigation mechanism effectively responded to soil moisture variations, contributing to efficient water management. The environmental monitoring and temperature-based fan control enhanced system adaptability. The integration of solar energy improved energy efficiency and system sustainability, making the solution suitable for remote agricultural applications. Additionally, the Wi-Fi communication module enabled remote monitoring, enhancing operational convenience.

Overall, the proposed system provides a practical, energy-efficient, and cost-effective solution for smart agriculture. The combination of sensing, automation, IoT connectivity, and renewable energy integration supports improved water management and sustainable agricultural practices.

### **REFERENCES**

1. Raj Kamal, *Internet of Things: Architecture and Design Principles*, McGraw Hill Education, 2017.
2. P. T. Kalaivani, R. Gopinath, "IoT Based Smart Irrigation System Using Raspberry Pi," *International Journal of Advanced Research in Computer and Communication Engineering (IJARCCE)*, Vol. 6, Issue 2, 2017.
3. S. R. Nandurkar, V. R. Thool, R. C. Thool, "Design and Development of Precision Agriculture System Using Wireless Sensor Network," *IEEE International Conference on Automation, Control, Energy and Systems (ACES)*, 2014.
4. Nisha P. Shetty, A. R. Kumar, "IoT Based Automated Irrigation System Using Sensors," *International Journal of Engineering Research & Technology (IJERT)*, Vol. 9, Issue 7, 2020.
5. S. Suresh, K. Eswaran, "Smart Agriculture System Using IoT and Cloud Computing," *International Journal of Scientific Research in Computer Science and Engineering (IJSRCSE)*, Vol. 8, Issue 3, 2020.
6. Chetan D. Londhe, Deepak P. Kadam, "Solar Tracking System Using Arduino," *International Journal of Innovative Research in Electrical, Electronics, Instrumentation and Control Engineering (IJIREEICE)*, Vol. 5, Issue 3, 2017.