

Off-Grid Power Monitoring System Using IOT

Sachin P. Nalawade¹, Vishwajeet K. Janjalkar², Pratik S. Suryawanshi³,
Aniket P. Shewale⁴, Nayan B. Salpekarkar⁵

¹Asst. Professor, Department of Electrical, Navsahyadri Group of Institutions, Pune, Maharashtra, India
^{2,3,4,5} Students, Department of Electrical Engineering, Savitribai Phule Pune University, Pune

ABSTRACT

Off-grid electrical systems are designed to generate and manage power independently without connection to a centralized utility grid. These systems are commonly deployed in rural regions, remote research stations, agricultural fields, and emergency backup applications. Although off-grid setups provide energy independence, monitoring their performance is often difficult due to limited supervision and physical accessibility. This research presents an Internet of Things (IoT)-enabled Off-Grid Power Monitoring System capable of measuring and transmitting real-time electrical parameters such as voltage, current, battery charge level, and load consumption. The system integrates a microcontroller-based data acquisition unit with wireless communication to send data to a cloud-based Platform for visualization and storage. The proposed framework enables continuous supervision, early fault detection, and performance optimization. Experimental implementation demonstrates reliable measurement accuracy, low deployment cost, and efficient remote monitoring capability. The system is suitable for small-scale renewable installations and enhances operational reliability of standalone power systems.

INTRODUCTION

Access to dependable electrical energy is a fundamental requirement for economic growth, communication, healthcare, agriculture, and education. However, in many rural and geographically isolated regions, extension of centralized grid infrastructure is technically difficult and financially impractical. As a result, off-grid renewable energy systems have emerged as a sustainable and decentralized solution for localized power generation.

An off-grid system operates independently of the national utility grid and typically consists of a solar photovoltaic (PV) array, charge controller, battery storage unit, and load interface.

Generate direct current (DC) electricity from solar irradiation and store excess energy in batteries for use during non-sunlight hours. Unlike grid-connected systems, standalone installations must manage generation, storage, and consumption internally without external support. This makes performance monitoring a critical requirement for ensuring system reliability and longevity.

One of the primary challenges in off-grid systems is effective energy management. Variations in solar irradiance, load demand fluctuations, and improper charging cycles can significantly affect battery life and overall system efficiency. Deep discharge conditions reduce battery lifespan, while overcharging can cause thermal stress and electrolyte degradation. Furthermore, undetected voltage instability and current overload may lead to component failure. Traditional monitoring approaches rely on manual inspection using measuring instruments such as multimeters, which is time-consuming, inefficient, and unsuitable for remote installations.

Recent advancements in embedded systems and wireless communication technologies have enabled the integration of Internet of Things (IoT) solutions in renewable energy applications. IoT-based monitoring systems allow continuous acquisition of electrical parameters such as voltage, current, and power, followed by real-time transmission to cloud platforms for storage and visualization. This approach provides remote accessibility, automated alert generation, historical trend analysis, and improved fault diagnosis capability.

The implementation of IoT in off-grid monitoring enhances operational transparency by enabling users to observe system behavior from any location with internet connectivity. Cloud-based dashboards provide graphical representation of energy generation and consumption patterns, assisting in performance optimization and preventive maintenance. Moreover, threshold-based alert mechanisms can notify users when battery voltage falls below safe operating levels or when abnormal current conditions occur.

Another significant advantage of IoT-enabled monitoring is scalability. The system can be deployed in small residential solar setups, agricultural irrigation pumps, telecom backup systems, rural microgrids, and disaster relief camps. Due to advancements in low-power microcontrollers and wireless modules, implementation cost has reduced considerably, making the technology accessible for small-scale applications.

Despite the growing adoption of renewable energy systems, limited research focuses on cost-effective and simplified monitoring architectures tailored for standalone installations in developing regions. Therefore, this study aims to design and implement a low-cost, reliable, and scalable IoT-based off-grid power monitoring framework. The proposed system continuously measures critical electrical parameters, processes data using an embedded microcontroller, and transmits information to a cloud server for real-time supervision.

By integrating sensing, processing, and wireless communication technologies, the proposed approach improves energy efficiency, enhances battery protection, reduces maintenance requirements, and increases the operational lifespan of off-grid renewable installations.

LITERATURE REVIEW

The rapid growth of renewable energy technologies has significantly increased the deployment of standalone solar power systems, especially in remote and rural areas. As these systems operate independently of centralized grids, reliable monitoring mechanisms are essential to ensure stable performance, efficient energy utilization, and long-term operational sustainability. Over the past decade, researchers have explored various approaches for integrating monitoring and communication technologies into renewable energy frameworks.

Early monitoring systems for off-grid installations primarily relied on manual inspection and basic analog measurement devices. These traditional approaches required physical presence at the installation site and did not provide real-time data accessibility. Although simple in implementation, such methods were inefficient for remote locations and failed to offer predictive maintenance capabilities.

With the advancement of embedded systems, microcontroller-based monitoring solutions were introduced. Researchers implemented voltage and current sensing modules connected to programmable controllers for periodic data acquisition. These systems improved measurement accuracy and automation; however, they often lacked remote connectivity features. Data logging was typically performed locally using SD cards or basic display interfaces, limiting the ability to perform long-term analytics or centralized supervision.

The introduction of wireless communication technologies such as GSM, Wi-Fi, Zigbee, and LoRa significantly enhanced monitoring capabilities. Several studies proposed GSM-based alert systems that transmit SMS notifications when battery voltage drops below predefined thresholds. While effective for basic fault alerts, these systems were limited in scalability and continuous data streaming capacity.

Cloud-based monitoring frameworks marked a major evolution in renewable energy supervision. Researchers developed IoT-enabled architectures capable of transmitting real-time solar and battery parameters to cloud servers using lightweight communication protocols. These platforms allowed users to visualize performance trends through web dashboards and mobile applications. Such systems demonstrated improved accessibility, centralized data storage, and enhanced analytical potential.

Battery monitoring has also been an important focus area in the literature. Studies emphasize the importance of tracking State of Charge (SoC), Depth of Discharge (DoD), and charging efficiency to prevent premature battery degradation. Advanced methods such as coulomb counting and model-based estimation techniques have been proposed to enhance battery health assessment. However, many of these solutions require complex algorithms and higher computational resources, increasing system cost.

METHODOLOGY

System Architecture Design:

The proposed system is structured into four primary layers: Energy Generation Layer, Sensing and Data Acquisition Layer, Processing and Communication Layer, Cloud and Visualization Layer. This layered architecture ensures modularity, scalability, and ease of maintenance.

Energy Generation Layer:

The energy source consists of a solar photovoltaic (PV) panel connected to a charge controller and battery storage unit. The PV panel converts solar irradiance into DC electrical energy. The charge controller regulates voltage and current to

prevent overcharging and deep discharge. The battery stores energy and supplies power to the connected load. This layer ensures stable and regulated power flow within the standalone system.

Sensing and Data Acquisition:

Accurate sensing is critical for system reliability. The following electrical parameters are continuously measured, Solar panel voltage, Battery voltage, Load, current, Instantaneous power.

Data Processing Unit

The microcontroller acts as the central processing unit of the system. Its responsibilities include: Reading sensor inputs, Converting analog signals to digital values, Applying calibration factors, Calculating electrical parameters, Generating alerts based on thresholds, Formatting data for transmission.

Wireless Communication Module:

The system uses a wireless communication interface (such as Wi-Fi or GSM) for remote data transmission. Communication Steps: Establish network connection, Package data in structured format (e.g., JSON), Transmit data using HTTP or MQTT protocol, Receive acknowledgment from cloud server. MQTT protocol is preferred for IoT applications due to: Low bandwidth usage, Lightweight architecture, Efficient publish-subscribe mechanism.

Experimental Setup: The prototype system was tested under controlled off-grid conditions. The setup included 12V solar panel, 12V lead-acid battery, Resistive DC load, Embedded microcontroller board, Wi-Fi-enabled communication module.

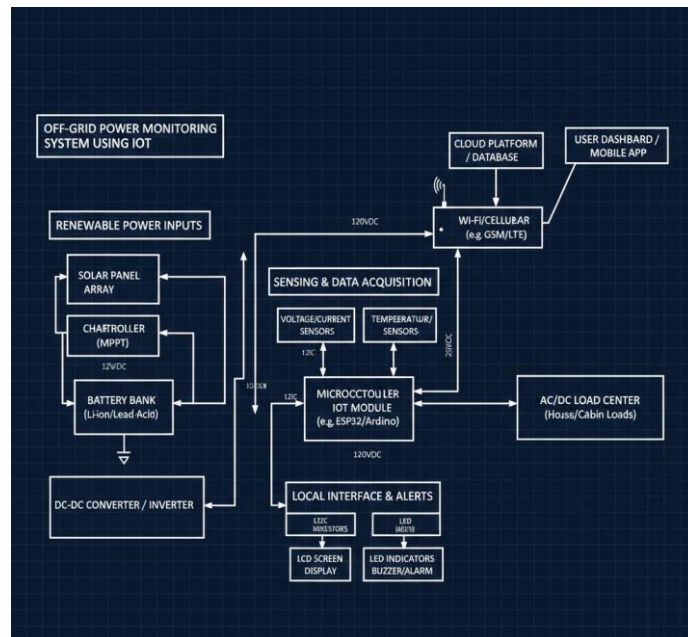

Fig: circuit diagram

The Off-Grid Power Monitoring System using IoT works as an independent energy management unit designed for locations where grid power is unavailable or unreliable. The system begins with renewable energy generation, typically through solar panels that convert sunlight into DC electricity. A Maximum Power Point Tracking (MPPT) charge controller optimizes the power output from the panels and regulates voltage to charge the battery bank efficiently. This prevents overcharging, deep discharge, and battery damage, thereby increasing battery lifespan and overall system efficiency.

The battery bank acts as an energy storage unit, supplying power when solar generation is low or unavailable (such as at night or during cloudy conditions). A DC-DC converter stabilizes voltage levels for DC loads, while an inverter converts DC power into AC for running standard household appliances. This ensures compatibility with both low-voltage DC devices and conventional AC equipment.

For monitoring and control, multiple sensors are integrated into the system. Voltage and current sensors measure power generation, battery charging/discharging rate, and load consumption. Temperature sensors monitor battery and environmental conditions to prevent overheating and improve safety. These sensor signals are sent to a microcontroller-based IoT module (such as ESP32 or Arduino), which performs real-time data acquisition, filtering, and preliminary

analysis. The controller can also implement control logic, such as disconnecting loads during low battery levels or triggering protective shutdowns during fault conditions.

The communication module (Wi-Fi or GSM/LTE) transmits collected data to a cloud platform or remote server. The cloud system stores historical data, performs advanced analytics, and generates performance reports such as daily energy production, battery health status, and load usage trends. Users can access this information through a web dashboard or mobile application, allowing remote monitoring from any location. Alert notifications (SMS, app alerts, or email) are generated in case of abnormal conditions like low battery voltage, overload, or high temperature.

Additionally, the system includes a local interface with an LCD display, LED indicators, and a buzzer alarm. These components provide instant on-site feedback about system status, faults, or warnings without needing internet connectivity. Overall, the system ensures efficient energy utilization, predictive maintenance, improved safety, and smart remote supervision.

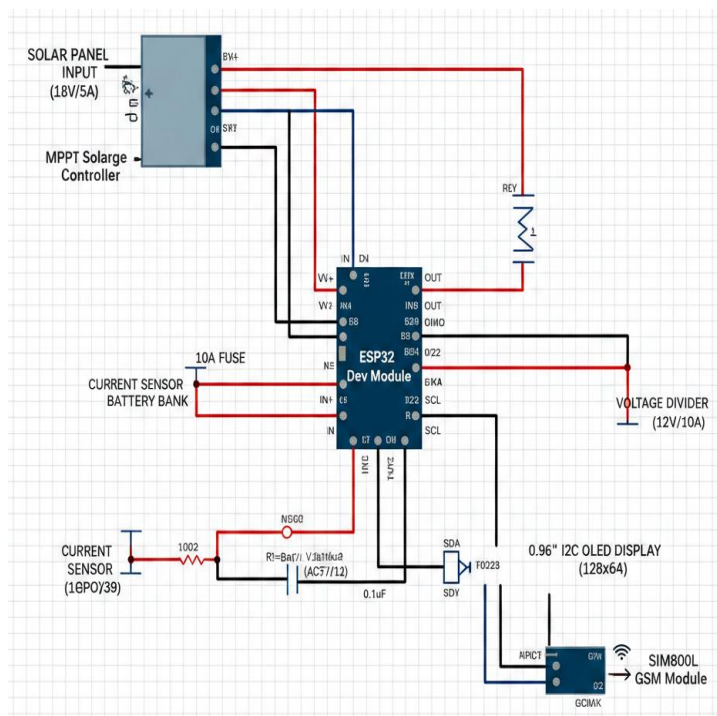

Components:

Sr. No.	Component	Function
1.	Solar panel	A solar panel contains multiple photovoltaic cells that convert sunlight into electricity.
2.	Voltage Sensor	A voltage sensor measures the electrical potential difference between two points in a circuit.
3.	Current Sensor	A current sensor detects the flow of electric charge passing through a conductor.
4.	Microcontroller	A microcontroller is a compact integrated circuit that contains a processor, memory, and input/output ports on a single chip.
5.	IOT Communication Module	An IoT communication module enables devices to send and receive data over networks such as Wi-Fi, GSM, or LTE.
6.	Display and Indicators	Displays and indicators provide visual feedback about a system's status, measurements, or operational conditions.
7.	Power Supply Components	These components ensure proper voltage conversion, smooth current flow, and protection for electronic circuits.

RESULT AND DISCUSSION

Measured Electrical Parameters:

Parameter	Observed Range	Unit
Solar Voltage	17 – 21	Volts
Battery Voltage	11.8 – 13.5	Volts
Load Current	0.5 – 3.2	Amperes
Output Power	10 – 65	Watts

The developed Off-Grid Power Monitoring System using IoT was implemented and tested to evaluate its efficiency and reliability. The solar panel produced sufficient electrical energy under normal sunlight conditions, while the MPPT charge controller optimized power extraction and maintained safe battery charging. The battery storage unit supplied uninterrupted power during low solar availability, ensuring stable operation of connected devices.

The voltage, current, and temperature sensors continuously monitored system parameters and delivered accurate readings. These measurements helped in assessing battery condition, load demand, and overall system performance. The sensor data remained consistent even during fluctuations in environmental and load conditions, indicating dependable operation. The microcontroller efficiently handled data collection, processing, and control functions. It executed programmed safety actions such as disconnecting loads during low battery levels and activating alerts during abnormal situations. This automation improved operational safety and minimized the need for manual intervention.

Data transmission through the IoT communication module was smooth and reliable. System information was successfully uploaded to the cloud platform, where it could be accessed through a web dashboard. Real-time updates and stored historical records allowed users to analyze energy generation, consumption trends, and battery health. Overall, the system demonstrated effective energy management, enhanced monitoring capability, and improved safety. The results indicate that the proposed model is suitable for remote and rural locations, offering a practical and economical solution for off-grid power supervision.

REFERENCES

- [1] K. R. Prasad and S. S. Kumar, "IoT-Based Solar Power Monitoring System for Smart Grid," *International Journal of Engineering Research & Technology (IJERT)*, vol. 9, no. 5, pp. 112–116, 2020.
- [2] M. Z. A. Abidin, N. H. M. Yusoff, and N. A. Othman, "Design of IoT-Enabled Solar Power Monitoring System," in *Proceedings of the IEEE International Conference on Smart Instrumentation, Measurement and Applications (ICSIMA)*, 2021, pp. 45–50.
- [3] F. A. Al-Adeeb and A. H. Abdullah, "Cloud-Based Monitoring of Solar Photovoltaic Systems Using IoT Platform," *International Journal of Renewable Energy Research (IJRER)*, vol. 9, no. 3, pp. 1342–1349, 2019.
- [4] R. Gupta, A. K. Sharma, and P. Singh, "Wireless Sensor Network and IoT Based Energy Management System for Solar PV," *Journal of Green Engineering*, vol. 10, no. 7, pp. 2890–2902, 2020.
- [5] S. K. Singh and V. K. Vaish, "Intelligent Solar PV Monitoring System Using IoT and Cloud Computing," *International Journal of Computer Applications in Technology*, vol. 68, no. 2, pp. 158–165, 2022.
- [6] A. Sahu and S. K. Behera, "IoT-Based Smart Renewable Energy Monitoring and Control System," *International Journal of Renewable Energy Development*, vol. 10, no. 1, pp. 123–131, 2021.
- [7] P. Verma and N. Kumar, "Real-Time Solar PV Monitoring Using Wireless Sensor Networks and IoT Technology," *International Journal of Advanced Research in Electrical, Electronics and Instrumentation Engineering (IJAREEIE)*, vol. 8, no. 4, pp. 562–569, 2020.