

180 Degree Solar Pannel Sun Tracking Device

Navnath S.Govekar¹, Mrunmai M.Sanas², Ujjwala V. Devgirikar³, Ankita A. Mote⁴,
Suhani S. Sadgar⁵

¹Head of the Department, Department of Electrical Engineering, Navsahyadri Group of Institutions, Pune, Maharashtra, India

^{2,3,4,5}Students, Department of Electrical Engineering, Navsahyadri Group of Institutions, Pune, Maharashtra, India

ABSTRACT

Solar energy is rapidly gaining notoriety as an important means of expanding renewable energy resources. As such, it is vital that those in engineering fields understand the technologies associated with this area. Our project will include the design and simulation of a arduino-based solar panel tracking system. Solar tracking allows more energy to be produced because the solar array is able to remain aligned to the sun. This system builds upon topics learned in this course. A working system will ultimately be demonstrated to validate the design. Problems and possible improvements will also be presented.

INTRODUCTION

(Nowadays green energy) has gained much importance because of the energy resource as fossil fuel price is fluctuating. Solar energy affords great potential for conversion into electric power, able to ensure an important part of the electrical energy needs of the planet. The conversion principle of solar light into Electricity, called Photo-Voltaic (PV) conversion, is not very new, but the efficiency improvement of the PV conversion equipment is still one of top priorities for many academic and/or industrial research groups all over the world. Solutions for improving the efficiency of PV conversion can be achieved by improving the solar cell configuration of a solar tracking system and its technologies. The solar tracking system that automatically adjusts the PV panel position based on the illumination with respect to the natural position of the Sun at different times of the day can be realized by a means of a DC Motor. A DC motor (servo motor) controlled by micro controller that is equipped with an algorithm to provide the tracking position, the proposed tracking system generates efficient energy compared to that of fixed system.

LITERATURE SURVEY

MsAyushi Nitin Ingole [1],in this paper is based on the use of solar panel coupled to a stepper motor to track the Sun so that maximum sun light is incident upon the panel at any given time of the day and year. This is better compared to fixed panel method that may not be so efficient. Moreover, the code is constructed using C++ programming language and targeted to Arduino.

UNO controller. The efficiency of the system has been tested and compared with static solar panel on several time intervals, and it shows the system react the best at the 10-minutes intervals with consistent voltage generated. Therefore, the system has been proven working for capturing the maximum sunlight source for high efficiency solar harvesting applications. Further the work can be enhanced by using RTC (Real Time Clock) to follow the Sun. This helps in maintaining the required position of the panel even if the power is interrupted for some time.

METHODOLOGY

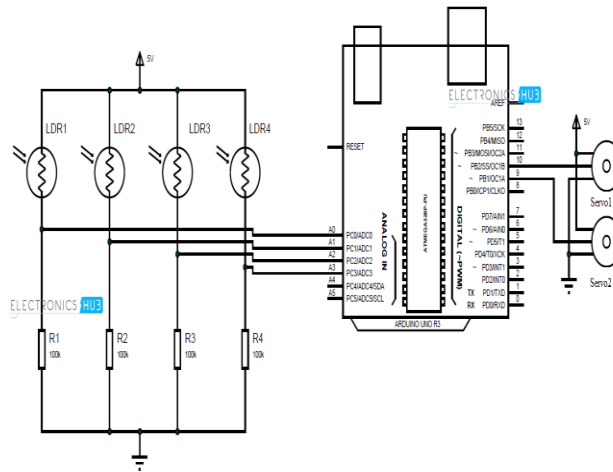

An automated dual axis solar tracking system by using Arduino is proposed. Here microcontroller controls the solar panel's movement which rotates and follows the motion of the sun anywhere in sky. There are three limit switches used in the circuit. Among which two are attached to the solar panel to mark its maximum angular positions in the east and west. The limit switch's status is read by microcontroller and the maximum angular position in either direction is indicated. When this position has been reached the panel should not be driven any further. And third limit switch is used to mark its angular position horizontally (i.e.360°). As the plane of the panel is always kept perpendicular to the direction of the sun, maximum amount of thermal energy can be obtained from the solar panel. Arduino is an open-source electronics prototyping platform based on flexible, easy-to-use hardware and software. This is specially designed for the ease of artists, designers, hobbyists, and anyone interested in creating interactive objects or environments. Arduino receives an input signal from different sensors to sense the Environment, and is able to affect its surroundings by controlling motors, lights, and other type of actuators.

ARDUINO UNO

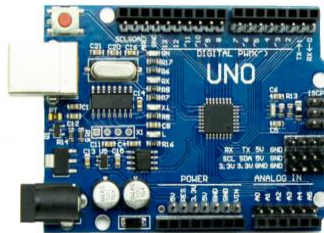

A microcontroller is a small computer on a single integrated circuit containing a processor core, memory, and programmable input/output peripherals. Microcontrollers are designed for embedded applications, in contrast to the microprocessors used in personal computers or other general purpose applications. A microcontroller is a compact microcomputer designed to govern the operation of embedded systems in motor vehicles, robots, office machines, automated sun trackers, and various other devices. A typical microcontroller includes a processor, memory, and peripherals. Arduino UNO R3 is a microcontroller board based on the ATmega328P will be used. It has 14 digital input/output pins (of which 6 can be used as Pulse Width Modulation [PWM] outputs), 6 analog inputs, a 16 MHz crystal oscillator, a USB connection, a power jack, an In-Circuit Serial Programming (ICSP) header, and a reset button. The UNO differs from all preceding boards because it does not use the FTDI USB-to-serial driver chip. This is what justifies the choice of UNO.

Servo Motor: (MG995)



A servomotor is a rotary actuator that allows for precise control of angular position. It uses a feedback mechanism to maintain its shaft position with minimum error. The servo motor has three wires. Among those 3 wires, 2 wires provide power supply to the motor and one is used to send signals to the motor for required shaft positions. These signals are PWM signal of varying duty cycle. Servo shaft is rotated by an angle depending on the ON-Time and off time of the pulse. Servo motors are used to rotate the solar panel by sending an electrical pulse of variable width, or pulse width modulation (PWM) through the control wire.

DC To Dc Converter : (Buck Converter)



This is the Buck converter used to change the voltage level from one to another. dc to dc buck converter operates as a step down system that will step down the high input voltage to low output voltage .

LDR Sensors

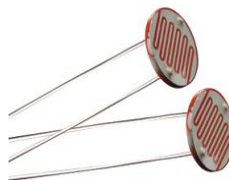

Light Dependent Resistor is made of a high-resistance semiconductor. It can also be referred to as a photoconductor. If light falling on the device is of the high enough frequency, photons absorbed by the semiconductor give bound electrons enough energy to jump into the conduction band. The resulting free electron conducts electricity, thereby lowering resistance. Hence, Light Dependent Resistors is very useful in light sensor circuits. LDR is very high-resistance, sometimes as high as $10M\Omega$, when they are illuminated with light resistance drops dramatically. It sense the light and give to arduino-uno.

Solar Plate :



CONCLUSION

This project has presented a means of controlling a sun tracking array. Specifically it demonstrates a working software solution for maximizing power output of the solar cell by positioning the system at the point of maximum light intensity. For energy reasons, as the main objective of this strategy is the generation of energy using sun as a source, the tracker is commanded to follow the sun at all times because this will cause continuous movement of the motors. Thus, the tracker waits for the sun. This process is identical and independent for each axis. However the two motors never move at the same time. Before ordering the movement of one axis, a check is made to ensure that the other axis is not moving. The two axes are not allowed to move simultaneously. As the sun moves along its trajectory throughout the day, signals from the light dependent resistors are sent so that appropriate motor moves appropriately, thus generating the electrical energy is designed to provide. The current sensor is used to confirm that the PV cell is tracking the sun correctly since it is measuring the power generated, so a decrease in the power generated (under normal external conditions, i.e. without taking into account an extended cloudy period, for example) indicates a tracking problem. It is known that the greater the error is in either of the two coordinates, the less power is generated. As a result, if the motor is on either of the coordinates (while the other is fixed) it can be assumed that the real position of the sun for that coordinates corresponds to the point where the maximum power was produced during the movement. This is why both motors cannot move simultaneously.

REFERENCES

- [1] "Novel high accurate sensorless dual-axis solar tracking system controlled by maximum power point tracking unit of photovoltaic systems" by Fathabadi, H. (2016)
- [2] "Performance evaluation of a multi-degree of freedom hybrid controlled dual axis solar tracking system" by Safan, Y.M., et al. (2018)
- [3] "A low-cost dual-axis solar tracking system based on digital logic design: Design and implementation" by Jamroen, C., et al. (2020)
- [4] Automatic Solar Tracking System: An Overview of Design and Fabrication" - ResearchGate (2020/2025)