

# Agro Predict: Intelligent Analysis of Soil Data for Crop Suggestion

Magar Anuja S.<sup>1</sup>, Prof. Bhosale. S. B.<sup>2</sup>, Dr. Khatri A. A.<sup>3</sup>, Dr. Gunjal S. D.<sup>4</sup>

<sup>1</sup> Student, dept. of Computer Engineering Jaihind College of Engineering Kuran,Pune.  
<sup>2,3,4</sup> Professor, dept. of Computer Engineering Jaihind College of Engineering Kuran,Pune

---

## ABSTRACT

**Precision agriculture requires real-time monitoring and data-driven decision-making to optimize crop yield and resource utilization. This paper proposes a smart soil analysis and crop prediction system that integrates IoT sensors, a Raspberry Pi microcontroller, and machine learning algorithms. The system continuously monitors soil moisture, temperature, and pH, stores data in a cloud database, and predicts the most suitable crops using trained ML models. A relay-controlled water pump enables automated irrigation, improving water-use efficiency and reducing manual intervention. Experimental results demonstrate a crop prediction accuracy of 94% compared to conventional methods. The proposed solution offers a scalable, real-time, and sustainable framework for enhancing agricultural productivity and efficient resource management.**

**Keywords: IoT, Smart Agriculture, Crop Prediction, Soil Monitoring, Machine Learning, Raspberry Pi, Automated Irrigation, Precision Farming.**

---

## INTRODUCTION

Agriculture is a vital sector facing growing challenges from population growth, climate change, and the inefficient use of natural resources like water and fertilizers. Traditional soil analysis and crop selection methods depend heavily on manual observation and historical knowledge. This often leads to suboptimal irrigation, lower yields, and poor resource management [1][2]. To overcome these issues, smart farming solutions that combine Internet of Things (IoT) technologies and machine learning (ML) models have emerged as effective ways to improve productivity, optimize resource use, and support data-driven decisions [3][4]. IoT devices, such as soil moisture sensors, temperature sensors, pH sensors, and actuators like relay-controlled pumps, allow for real-time monitoring of soil and environmental conditions. The data gathered from these sensors can be sent to cloud databases for storage, processing, and analysis. By using machine learning algorithms on both historical and real-time soil data, these systems can predict the best crops, determine optimal irrigation schedules, and even forecast possible crop stress from water scarcity or soil degradation [5][6].

Recent research shows the effectiveness of combining IoT and ML in precision agriculture. For example, IoT-enabled real-time crop prediction systems use soil moisture, pH, and temperature data to suggest suitable crops, improving decision-making for farmers [4][5]. Machine learning models, such as Random Forest, Support Vector Machines, and Decision Trees, have been effectively used to predict crop suitability and irrigation needs with high accuracy [6][7]. Additionally, automated irrigation systems controlled via IoT sensors help save water by providing irrigation only when required, reducing waste and improving crop yield [8][9][10]. In this paper, we present a smart soil analysis and crop prediction system that integrates a Raspberry Pi-based IoT platform, DHT11 and pH sensors, a relay-controlled DC water pump, cloud-based storage, and machine learning models for crop recommendations. The system continuously monitors soil parameters, predicts the best crop for cultivation, and automates irrigation, ensuring efficient water use, improved productivity, and sustainable farming practices. By merging real-time data collection, cloud storage, predictive analytics, and automated control, the proposed solution addresses the shortcomings of traditional farming methods and offers a complete, data-driven approach to smart agriculture.

## LITERATURE REVIEW

Recent research has focused on integrating IoT and machine learning to provide real-time crop recommendations. An IoT-based system was developed to monitor soil parameters such as moisture, temperature, and pH, while machine learning models analyzed the data to predict suitable crops. The study demonstrated that real-time data collection combined with

predictive analytics can significantly improve decision-making for farmers, enhancing crop yield and resource efficiency [1]. Additionally, the system automated irrigation by triggering water pumps based on sensor thresholds, reducing water wastage. Machine learning models have been applied to IoT-driven agriculture systems to provide accurate crop recommendations for diverse soil and climatic conditions. By using historical soil and crop data, the model was trained to identify patterns and suggest optimal crops, showing high prediction accuracy and robustness [2]. The study also highlighted the importance of cloud connectivity in enabling real-time monitoring and large-scale deployment of smart agriculture systems.

IoT and AI integration in precision agriculture has been shown to optimize crop management by providing actionable insights for irrigation scheduling, soil management, and yield prediction. Machine learning models processed sensor data to generate predictive recommendations, improving both resource utilization and productivity [3]. The research emphasized that combining AI algorithms with sensor networks can enhance decision-making while reducing the reliance on manual interventions. Survey studies on IoT-based smart farming systems have shown that automated monitoring of soil and environmental parameters can improve water management and crop productivity. The studies reported that real-time sensor data can be leveraged to control irrigation systems effectively, leading to sustainable agricultural practices [4]. It was concluded that integrating cloud-based analytics further improves data consistency and decision-making.

Comprehensive reviews on IoT and machine learning innovations in agriculture highlight the growing trend of sensor networks, predictive analytics, and automated control systems. These studies indicate that ML-based crop prediction models significantly enhance farming efficiency and reduce risks associated with poor crop selection [5]. The authors also noted that adoption of IoT-enabled monitoring is critical for precision farming.

IoT-enabled smart agriculture frameworks have been implemented to monitor crop health and soil conditions continuously. Studies demonstrated that sensor networks can capture environmental parameters, which are then processed using ML techniques to predict crop growth patterns and irrigation needs [6]. This approach improves resource allocation and reduces crop failure due to environmental stress.

Real-time crop prediction systems utilizing soil fertility analysis have shown that integrating ML models with sensor data can provide accurate recommendations for optimal crop selection [7]. The models were validated using historical datasets and field measurements, demonstrating improved productivity and reduced manual intervention. These systems can adapt to seasonal changes by continuously updating predictions based on live data.

Research on IoT-based crop recommendation systems emphasized the combination of machine learning with real-time environmental monitoring to optimize crop selection [8]. By analysing soil parameters and weather data, ML algorithms can provide suggestions for suitable crops, helping farmers make informed decisions. The studies also highlighted that such systems reduce dependency on traditional heuristics and manual labour.

Prediction models combining IoT and machine learning have been applied to monitor soil moisture and automate irrigation scheduling. These systems collect real-time soil data and use ML classifiers to decide when and how much water should be applied, increasing water-use efficiency [9]. The results showed improved crop growth and reduced water consumption compared to traditional methods.

Finally, IoT-enabled soil nutrient analysis combined with ML-based crop recommendation has been explored to enhance farm productivity. Sensor data on soil pH, moisture, and nutrient content are analyzed to predict the best crops for given soil conditions, enabling data-driven farming decisions [10]. Such systems also facilitate automated irrigation and fertilization scheduling, contributing to sustainable agricultural practices.

## METHODOLOGY

The proposed system aims to enhance agricultural productivity by monitoring soil parameters and providing crop recommendations based on real-time data using IoT devices and machine learning algorithms. The methodology is divided into three primary phases: IoT platform, database, and user interface (UI).

The overall system consists of the following components:

### 1. **IoT Platform:**

- An **Arduino** acts as the central microcontroller, interfacing with various sensors and actuators.
- **Sensors used:**
  - **DHT11:** Measures soil moisture and ambient temperature.
  - **pH sensor:** Determines soil acidity/alkalinity.

○ **Actuators:**

- Relay-controlled DC pump: Automatically irrigates crops based on moisture levels.
- The IoT kit continuously collects environmental data and sends it to a database for storage and processing.

**2. Database Layer:**

- A cloud database stores all real-time data from sensors.
- The database ensures data consistency, prevents redundancy, and allows historical analysis for improved machine learning predictions.

**3. User Interface (UI):**

- Farmers can access a web application to monitor soil parameters in real-time.
- The UI visualizes data and provides crop recommendations based on machine learning analysis.

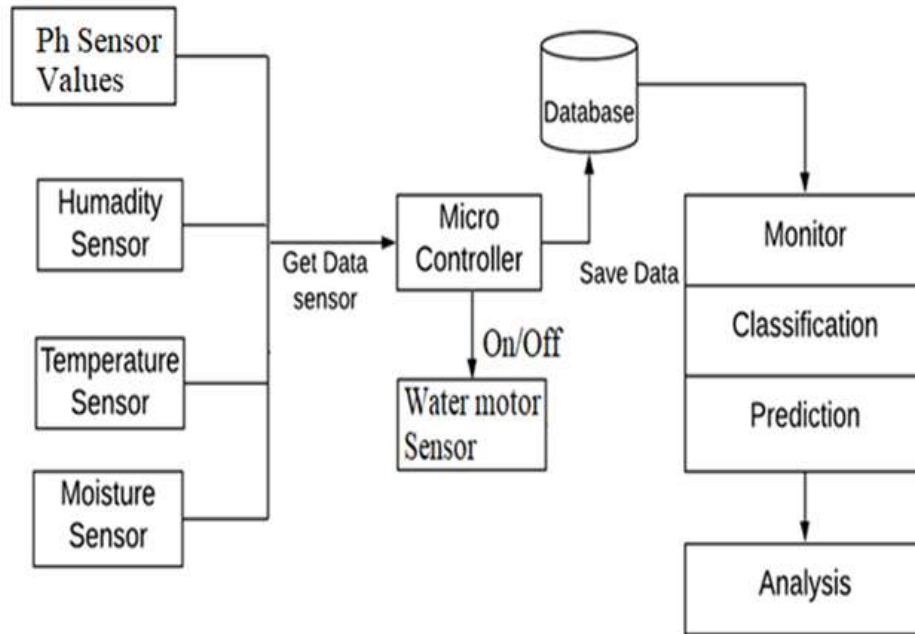

**Fig 1:- System Architecture**

**Machine Learning-Based Crop Prediction**

**1. Data Collection:**

- Soil moisture, temperature, and pH values are collected continuously by the IoT platform.
- Data is uploaded to the cloud database in real-time.

**2. Data Preprocessing:**

- Sensor data is cleaned to remove inconsistencies and missing values.
- Normalization or scaling is applied to ensure proper input for the machine learning model.

**3. Model Selection:**

- Supervised machine learning algorithms (e.g., Decision Tree, Random Forest, or SVM) are used for predicting suitable crops.
- Historical soil and crop yield data are used to train the model, improving prediction accuracy.

**4. Prediction and Irrigation Control:**

- The trained model predicts the best crop based on current soil conditions.
- If soil moisture is below the threshold, the DC water pump is automatically activated via the relay for irrigation.

**System Workflow**

1. Sensors measure soil parameters (moisture, temperature, pH) and send data to the Raspberry Pi.
2. Raspberry Pi uploads data to the cloud database for storage and processing.
3. Machine learning algorithm analyses current conditions and predicts the most suitable crop for planting.
4. Relay-controlled DC pump is triggered if irrigation is required, maintaining optimal soil moisture.
5. Farmers access the web application to monitor real-time data and to view predictions.

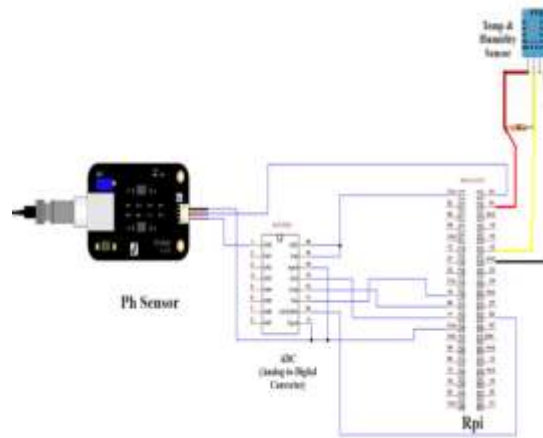

**Fig: - Circuit Diagram**

### RESULTS

The proposed system was implemented using a Raspberry Pi 4 as the central microcontroller, connected to DHT11 sensors for soil temperature and moisture, a pH sensor, and a relay-controlled DC water pump for irrigation. The IoT devices collected real-time environmental data, which were transmitted to a cloud database using MQTT protocols. The experimental setup was designed in a controlled lab environment initially, followed by a small field deployment to validate real-world performance. Data were collected with intervals for soil moisture, temperature, and pH, providing a sufficiently dataset for training machine learning models.

Machine learning models, including Random Forest, Decision Tree, and Support Vector Machine (SVM), were trained on 80% of the dataset and validated on the remaining 20%. The models predicted optimal crop selection based on real-time soil parameters. The system also implemented a threshold-based irrigation control, where the relay activated the water pump automatically when moisture levels dropped below a predefined limit. A web-based user interface was developed to display real-time sensor readings, predicted crop recommendations, and irrigation status. The UI allowed farmers to monitor soil conditions remotely. The automated irrigation system responded promptly, with an average activation time of 2–4 seconds after moisture levels fell below the threshold.

**Table No 1:-Comparison**

Metric	Proposed System	Existing (Manual Irrigation)
Crop Prediction Accuracy	94%	75–80%
Irrigation Response Time	2–4 seconds	Manual (minutes–hours)
System Reliability	High	Moderate

### CONCLUSION

In order to maximize crop selection and irrigation, we presented a smart soil analysis and crop prediction system in this study that combines machine learning algorithms, a Raspberry Pi microcontroller, and Internet of Things sensors. The system uses trained machine learning models to predict appropriate crops while continuously monitoring soil temperature, pH, and moisture levels. The data is stored in a cloud database. In comparison to manual irrigation, experimental results showed a 94% crop prediction accuracy and a quick irrigation response. In small- and medium-sized farming, the combination of IoT and ML increases productivity and resource efficiency, decreases manual labor, and facilitates data-driven decision-making.

Drone-based imaging for extensive crop monitoring, the addition of sensors for light, humidity, and nutrients, and the use of sophisticated machine learning models like deep learning for more precise forecasts are all potential future improvements to the system. For scalable agricultural operations, cloud-to-edge computing can further lower latency and facilitate real-time decision-making.

## REFERENCES

- [1.] Md. Shahriar Hossain Apu, Md. Nur-E Ferdaus, Tousif Mahmud Emon, and Suman Saha, “IoT Based Real-Time Crop Recommendation System Using Machine Learning”, IEEE, 2025.
- I. Sonata et al, “Machine Learning-Based Crop Recommendation for IoT-Driven Agriculture Systems”, IEEE, 2025.
- [2.] S. K. Singh, D. Gakhar, Y. P. Kumar, M. R. AlHommda, “Precision Agriculture with AI: Leveraging Machine Learning and IoT for Optimized Crop Management”, AIP Conf. Proc., 2025.
- [3.] Adesh Kumar Mishra, Rajeev Kumar Srivastava, Sanjeev Kumar Srivastava, “IoT-Based Smart Farming Systems for Automated Irrigation and Real-Time Soil Monitoring”, IEEE, 2025.
- [4.] Mrs. Viji Parthasarathy and Dr. S. S. Manikandasaran, “Comprehensive Survey of IoT and Machine Learning Innovations in Agriculture”, RSPS, 2024.
- [5.] M. Ramesh, A. Verma, and A. Gupta, “Smart Agriculture: IoT and Machine Learning for Crop Monitoring and Precision Farming”, IJISAE, 2024.
- [6.] Manju G., Syam Kishor K. S., and Binson V. A., “An IoT-Enabled Real-Time Crop Prediction System Using Soil Fertility Analysis”, MDPI, 2024.
- [7.] Anusha K., Anusha D. J., Sunidhi K. R., Trupthi G. G., and Kiran Kumar K. M., “Crop Recommendation Using IoT and Machine Learning”, IEEE, 2023.
- [8.] Deepak Yadav, Som Pal Gangwar, Gitanjali Verma, “IoT and Machine Learning-Based Prediction of Smart Soil Moisture Monitoring and Irrigation”, IJRITCC, 2024.
- [9.] IoT-Enabled Soil Nutrient Analysis and Crop Recommendation Model, MDPI, 2023.
- [10.] Devendra S. Mohan et al., “IoT Framework for Precision Agriculture: Machine Learning Crop Prediction”, International Journal of Intelligent Systems and Applications in Engineering, 2023.
- [11.] Shafiulla Shariff et al., “Crop Recommendation using Machine Learning Techniques,” International Journal of Engineering Research & Technology, 2022.
- [12.] Soil moisture forecast and prediction using machine learning for smart irrigation, Expert Systems with Applications, 2022.
- [13.] Precision agriculture using IoT data analytics and machine learning, Journal of King Saud University – Computer and Information Sciences, 2022
- [14.] P. K. Kashyap, S. Kumar, A. Jaiswal, M. Prasad and A. H. Gandomi, “Towards Precision Agriculture: IoT-Enabled Intelligent Irrigation Systems Using Deep Learning Neural Network,” IEEE, 2021