

Evaluation of the reliability indices 400 Kv Iraqi Super Grid

Mohammed Sabri A. Raheem

Assist. Prof., College of Electrical & Electronics Techniques
Foundation of Technical Education, Baghdad, Iraq

Abstract: This paper deals mainly with the calculation of the reliability indices of the Iraqi 400 KV super grid based on the operating data of the network using the path tracing method as a reliability calculation method. Hence concluding the main operative circumstances governing the operation of the grid & finding the poor reliability zones of the net work .It is of importance to form a suggestions & technical solutions to improve the reliability performance of the grid.

Keywords: Reliability Indices, Path Tracing Method, Iraqi 400 KV super grid

Introduction

The basic idea to notice in the reliability is that, it depends on a statistical probability, so on studying reliability it is dealt with the laws of random chance as they appear in nature. Indeed the occurrence of interruptions in function ability or service in a system is random events, the expected reputations of which, is aimed to be reduced.

The next thing to notice is that reliability depends on a specified mathematical relations, operating conditions, environmental conditions , and time. So before reliability can be calculated, the electric supplier & load centers must reach formal agreements on the behavior of the network administrator & distribution centers during the abnormal operating conditions (faults or any external conditions) ,and the procedures needs to operate the system correctly.

Complex system, such as substations are zones of interconnection between of transmission, sub transmission and distribution systems. The most suitable method for quantifying their ability to perform those functions is to find a statistical data for the occurrence, duration, location of faults before designing the electric system.

In simple systems, visual identification can be normally accomplished with less difficulty. The problem of identification becomes more difficult for larger and more complicated systems. The method of calculation of reliability indices performed in this paper is the Path Tracing Method (PTM), which is one of basic three methods of reliability parameters evaluation [1], which depends mainly on deducing a Minimum Cut Sets (MCS) and is implemented on a digital computer program to calculate the reliability indices parameters [1].

The above reliability calculations are applied on the 400 KV Iraqi super grids, hence finding the poor reliability zones & suggestions to improve the operation of the network based on a reliability point of view is also offered.

Parameters Description of the Iraqi 400KV Super Grid

The Iraqi electrical national grid consists of 400KV super grid and 132 KV Ultra High Voltage (UHV) electrical power transmission networks, & it consists of 33 KV and 11 KV system distribution networks. Iraqi electrical power system is divided, from operation and control point of view, into three operational subsystems; namely the north region, the middle region and south region, these three subsystem are operate and controlled as a unified interconnected system by National Dispatch Center (NDC) at same time, the above region subsystems are operated locally by other two regional control centers. This is shown in fig. (1). Basically it is noted that :

Iraqi national Extra High Voltage grid (EHV) system comprises (22) bus bars, (29) main transmission line, (19), 400/132 KV transformers .This is shown in fig (1).

Ten generating stations are connected to 400KV Iraqi super grid with peak capacity of (3800 MW), and generating stations are connected to 132 KV Iraqi network with peak capacity of (1367.1 MW), reaching a gen. capacity (5167.1 MW) while the demand load reaches the limit of (11000 MW). In this paper the reliability of 400 KV Iraqi super grid based on the data, is calculated after dividing the national network to six zones, as in fig.(1), named as (Iraqi north), (Dyala - Anbar), (Baghdad north), (Baghdad south), (Iraqi south), and (Iraqi middle) zones. This representation is found to be close to the updated connection of the network.

Failure Rate & Repair Rate Network Data

The technical data of the Iraqi network generating stations obtained from the planning office of (The Establishment of Generation & Production of Electric Energy), is given in table (1). The (failure rate, repair rate and mean dead time) data is also shown in table (1).

Reliability Modeling & Evaluation of the Iraqi 400 KV Network

The network of fig (1) is classified into SIX zones which represent the close practical operating condition of the network. To find the reliability indices of the network the following procedure is followed:

1) For each zone & to apply the PTM reliability procedure calculations, the power flow paths & the minimal cut sets are found .Hence finding the reliability index (R) and the AAIR which represent the Average Annual Interruption Rate of the zones . Table (2) gives the summary of the above calculations .Then applying the connection diagram of fig (1) the total reliability index of the network is calculated as in (2) below.

2) The six subsystems are considered fully redundant. From analysis of Iraqi 400KV super grid, it is concluded that the equivalent reliability block diagram for the total 400KV Iraqi network is as shown in figure (1), and applying the equations:

$$R_{Series} = \prod_{i=1}^n R_i \dots\dots\dots (1.1)$$

$$Q_{Series} = 1 - \prod_{i=1}^n R_i \dots\dots\dots (1.2)$$

$$R_{parallel} = \prod_{i=1}^n 1 - Q_i \dots\dots\dots (1.3)$$

$$Q_{parallel} = \prod_{i=1}^n Q_i \dots\dots\dots (1.4)$$

Notation:

- R1 Iraqi North zone reliability index
- R2 Dyala -Anbar zone reliability index
- R3 Baghdad North zone reliability index
- R4 Baghdad South zone reliability index
- R5 Iraqi Middle zone reliability index
- R6 Iraqi South zone reliability index

From the above equations, and relationships between regions it can conclude this equations:

$$R7=R1*R2*R3 \dots\dots(1.5)$$

$$R8=R4*R5*R6 \dots\dots (1.6)$$

$$R_{total}=1-[(1-R7)*(1-R8)] \dots(1.7)$$

The adjacent matrices of the 400KV Iraqi super grid of Iraqi north region, Dyala and Anbar region, Baghdad north region, Baghdad south region, Iraqi middle region, and Iraqi south region are shown in tables above, which is input data to the first computer program, the output results are also shown in tables above, from these tables it is noted that there are Minimal Cut Sets (MCSs), the reliability characteristics are generally dominated by the low order minimal cut sets because have high probability of occurrence than the higher orders minimal cut sets.

The results of first program can be used as inputs to the second program to calculated the reliability characteristics; Therefore the unreliability, reliability and AAIR of the each region for one year shown in tables above , from those tables it is noted that the reliability decreases as the time increases and AAIR increases as the unreliability increases.

From the presented work, it is noted that the average of generated electrical power in 2009 is 4039MW while the Average load demand is 7838.6MW. The reliability of Total Iraqi 400KV network in 2009 is 0.512756 because, there is out the serves lines, failure in the required generating of load demand and management failure.

Conclusions

From the results obtained above the following conclusions are summarized:

- 1) The over all reliability index of the network is very low (51.27 %) & this is because of the main loss of the ideal ring system criteria because of the loss of many 400 KV lines & poor link between zones.
- 2) The least reliability index is reached in the Dyala-Anbar zone (1.95 %) ,this occurs because of the poor connection with the national grid & the loss of many 400 KV transmission lines.

In order to try to improve the reliability operative performance of the network it is of most importance to reconnect the broken lines & add more 400 KV transmission lines in the poor reliability index zones & increase the link between zones to improve the total reliability index of the network .

References

- [1]. Paul Kalas, "Reliability for Technology Engineering and Management" prentice-Hall,1998. Allan.
- [2]. Roy Billinton and Ronald N. "Reliability Evaluation of Power System", pitman advanced publishing program, 1984.
- [3]. Nadim Kasem Rahim, "Reliability Study of the Northern West Iraqi Super Grid", HN.D. thesis, Electrical and electronic college techniques, department electrical power engineering, 2008.
- [4]. Republic of Iraqi / Ministry of Electricity / Training and Development office / Control and Operation Office.
- [5]. M. Vujosevic & D. Meade, "Reliability Evaluation & Optimization of Redundant Dynamic Systems "IEEE Trans. On Reliability,Vol. R-34,No.2,June 1985.
- [6]. G.Szabo & P.Gaspar,"Practical Treatment methods for Adaptive components in Fault Tree Analysis", IEEE Proceedings on Annual Reliability & Maintainability Symposium, 1999 ,pp 97-104.
- [7]. Ihsan J. Hasan, "A proposed Method For Reliability Evaluation Based on PTM", M.Sc.Thesis, College Of Electric & Electronic Techniques , Baghdad, 2007.
- [8]. Qais M. Aish, "Reliability Calculation Of The Iraqi Super Grid", M.Sc.Thesis, College Of Electric & Electronic Techniques, Baghdad, 2009.

Table (1) Input Data

Co. No.	Component Name	Failure Rate $\lambda, (\text{hr}^{-1})$	Repair Rate $\mu, (\text{hr}^{-1})$	Mean Dead Time(hr)
1	Mosul Dam	1.465e-4	5.1668e-4	1935.4
2	Baiji P.S.	1.864e-4	2.9436e-4	3397.1
3	Baiji G.P.S.	1.518e-4	2.0876e-4	4790
4	Kirkuk G.P.S.	1.569e-4	4.1869e-4	2388.4
5	Hadiytha Dam	1.104e-4	3.9577e-4	2526.7
6	Qudis G.P.S.	1.035e-4	2.7547e-4	3630.1
7	Musayab P.S.	1.328e-4	8.1149e-4	1232.3
8	Nassiriya P.S.	1.52e-4	4.5827e-4	2182.1
9	Hartha P.S.	1.573e-4	4.155e-4	2406.7
10	Khor-Alzuber P.S.	1.343e-4	7.5895e-4	1317.6
11	Mosul Dam – Mosul	6.7e-6	3.2746e-4	3053.8
12	Mosul – Baiji P.S.	19.604e-6	3.2814e-4	3047.4
13	Baiji P.S. – Baiji G.P.S.	13.424e-6	2.777e-3	360
14	Baiji G.P.S. – Kirkuk	/	/	/
15	Baiji P.S.–Hadiytha Dam	/	/	/
16	Hadiytha Dam – Qam	/	/	/
17	Kirkuk – Dyala	/	/	/
18	Hartha – Khor-Alzuber	5.817e-6	7.6028e-4	1315.3
19	KhorAlzuber–Nassiriya	32.39e-6	6.8624e-4	1457.2
20	Hartha – Kut	46.347e-6	4.5804e-4	2183.2
21	Nassiriya – Kut	31.867e-6	9.6655e-4	1034.6
22	Nassiriya – Kadisiyah	28.751e-6	5.3143e-4	1881.7
23	Musayab – Babil	3.62e-6	7.2849e-4	1372.7
24	Babil – Kadisiyah	19.604e-6	4.9251e-4	2030.4
25	Hadiytha Dam–BG. West	35.735e-6	2.3847e-4	4193.3
26	Baiji P.S. – BG. West	35.5433e-6	2.2983e-4	4350.9
27	Qudis – BG. North	2.125e-6	1.1038e-4	905.9
28	Dyala – BG. East	5.593e-6	5.4451e-4	1836.5
29	Musayab – BG. South	5.7e-6	2.1234e-4	4709.4
30	Musayab–MusayabG.P.S	/	/	/
31	MusyabG.P.S–BG.South	/	/	/
32	Kadisiyah – BG. South	21.655e-6	2.2089e-3	452.7
33	Kut – BG. South	18.139e-6	4.7655e-4	2098.4
34	BG. North – BG. West	6.8721e-6	4.3508e-4	2298.4
35	BG. North – BG. East	2.125e-6	7.7071e-4	1297.5
36	Alameen – BG. East	2.125e-6	6.6352e-4	1507.1
37	BG. South – Alameen	6.8721e-6	6.942e-4	1440.5
38	BG. South – BG. East	7.751e-6	8.3333e-4	1200
39	BG. West – BG. South	10.627e-6	1.2888e-3	775.9
40	Mosul Transformer	1.522e-6	5.2246e-4	1914
41	Baiji Transformer	1.522e-6	0.005	200
42	Kirkuk Transformer	1.014e-6	1.4285e-4	700
43	Qam Transformer	/	/	/
44	Hadiytha Transformer	1.522e-6	3.3057	302.5
45	Dyala Transformer	1.014e-6	0.005	200
46	KhorAlzuber Transfomer	1.20159e-6	0.005	200
47	Hartha Transformer	1.522e-6	0.005	200
48	Amara Transformer	/	/	/
49	Nassiriya Transformer	1.522e-6	2.0833e-3	480
50	Kadisiya Transformer	1.014e-6	1.3386e-3	747

51	Babil Transformer	1.20159e-6	0.005	200
52	Musayab Transformer	1.014e-6	0.005	200
53	Kut Transformer	1.522e-6	1.6666e-3	600
54	BG. West Transformer	1.014e-6	4.7147e-4	2121
55	BG. North Transformer	1.014e-6	4.99e-4	2004
56	BG. East Transformer	1.014e-6	1.0224e-3	978
57	Alameen Transformer	1.522e-6	8.5433e-4	1170.5
58	BG. South Transformer	1.014e-6	8.0906e-4	1236

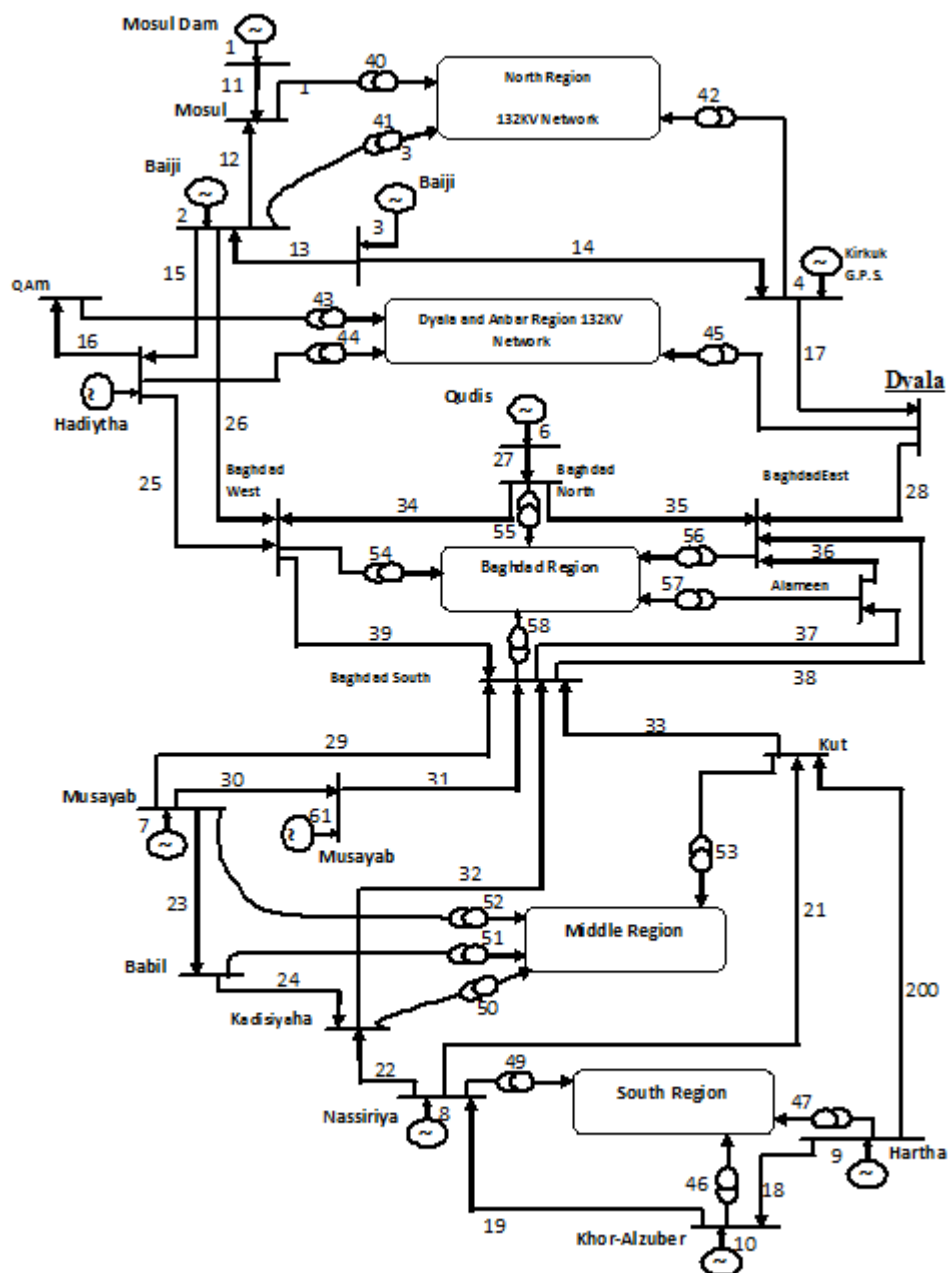

Figure (1) Iraqi 400kV Super Grid

Table 2: The reliability analysis results of the Iraqi 400 Kv network

Net work region	Power flow paths	Minimal cut sets & orders	
Iraq North Region Reliability= 32.391% AAIR=246.77 day	1. 2+41 2. 4+42 3. 3+13+41 4. 1+11+40 5. 2+12+40 6. 3+13+12 +40	3 rd	{4,40,41},{40,41,42}
		4 th	{1,2,3,4},{1,2,3,42},{1,2,4,13},{1,2,13,42}, {1,4,12,41},{1,12,41,42},{2,3,4,11},{2,3,4,40}, {2,3,11,42},{2,3,40,42},{2,4,11,13},{2,4,13,40}, {2,11,13,42},{2,13,40,42},{4,11,12,41},{11,12,41,42}
		3 th	{7,22,53},{7,50,53}
		4 th	{7,8,9,10},{7,8,919},{7,8,19,20},{7,8,19,53}, {7,9,21,22},{7,9,21,50},{7,20,21,22}, {7,20,21,50},{22,23,52,53},{23,50,52,53}, {50,51,52,53}
		5 th	{7,8,10,18,20},{7,8,10,18,53},{8,9,10,23,52}, {8,9,19,23,52},{8,19,20,23,52}, {8,19,23,52,53},{9,21,22,23,52},{9,21,23,50,52}, {9,21,50,51,52},{20,21,22,23,52}, {20,21,23,50,52},{20,21,50,51,52}, {22,24,51,52,53}
Iraqi South Region Reliability= 68.071% AAIR=116.54 day	1. 8+49 2. 10+19+49 3. 9+18+19 +49 4. 10+46 5. 9+18+46 6. 9+47	3 rd	{8,9,10},{9,10,49},{9,46,49},{46,47,49}
		4 th	{8,9,19,46},{8,10,18,47},{8,19,46,47}, {10,18,47,49}
Dyala- Anbar Region Reliability= 1.9563% AAIR=357.86 day	1. 5+44	1 st	{5},{44}

Baghdad North Region Reliability=6.3430% day AAIR=341.83	1. 1+11+40 2. 2+12+40 3. 3+13+12+40 4. 2+41 5. 3+13+41 6. 4+42	3 rd	{5,6,26},{5,26,27},{6,25,26},{6,39,54},{6,54,58}, {25,26,27},{27,39,54},{27,54,58}
		4 th	{2,3,5,6},{2,3,5,27},{2,3,6,25},{2,3,25,27}, {2,5,6,13},{2,5,13,27}{2,6,13,25}, {2,13,25,27},{35,39,54,55},{35,54,55,58}, {39,54,55,56}, {54,55,56,58}
		5 th	{5,26,34,35,55},{5,26,34,55,56},{25,26,34,35,55},{25,26,34,55,56}
Baghdad South Region Reliability= 84.359% AAIR=57.09 day	1. 7+29+37 +36+56 2. 7+29+38 +56 3. 7+29+37+57 4. 7+29+58 5. 8+22+32+37 +36+56 6. 8+22+32+38 +56 7. 8+22+32+37 +57 8. 8+22+32+58 9. 8+21+33 +37+36+56 10. 8+21+33 +38+56 11. 8+21+33 +37+57 12. 8+21+33+58 13. 10+19+22+32+37 +36+56 14. 10+19+22+32+38 +56 15. 10+19+22+32+37 +57 16. 10+19+22+32+58 17. 10+19+21+33+37+36+56 18. 10+19+21+33+38+56 19. 10+19+21+33+37+57 20. 10+19+21+33+58 21. 9+20+33+37+36+56 22. 9+20+33+38+56 23. 9+20+33+37+57 24. 9+20+33+58	3 rd	{7,22,33},{7,32,33},{22,29,33},{29,32,33}, {37,38,58},{37,38,58},{37,56,58} ,{56,57,58}
		4 th	{7,8,9,10},{7,8,9,19},{7,8,10,20},{7,8,10,30}, {7,8,19,20},{7,8,19,33},{7,9,21,22},{7,9,21,32}, {7,20,21,22},{7,20,21,32}, {8,9,10,29},{8,9,19,29},{8,10,20,29}, {8,10,29,33},{8,19,20,29},{8,19,29,33}, {9,21,22,29},{9,21,29,32},{20,21,22,29}, {20,21,29,32},{36,38,57,58}