

Design & Characterization of Microstrip Balanced Mixer

Manidipa Nath, AIACTR, Delhi
manidipa.deoghar@gmail.com

INTRODUCTION

The mixer is one of the basic building blocks of any communication receiver and transmitters. Mixer is an important component in a heterodyne transceiver system because it translate signals from one frequency band to another. The output of the mixer consists of multiple images of the mixers input signal where each image is shifted up or down by multiples of the local oscillator (LO) frequency. The most important mixer output signals are usually the signals translated up and down by one LO frequency. The purpose of the mixer is to down-convert the RF frequency signal to the baseband for digitization and thus further processing. In reality mixer output is distorted due to non-linearity in the mixer. In addition, the mixer components and a non-ideal LO signal introduce more noise to the output. Bad design might also cause leakage effects, complicating the design of the complete system.

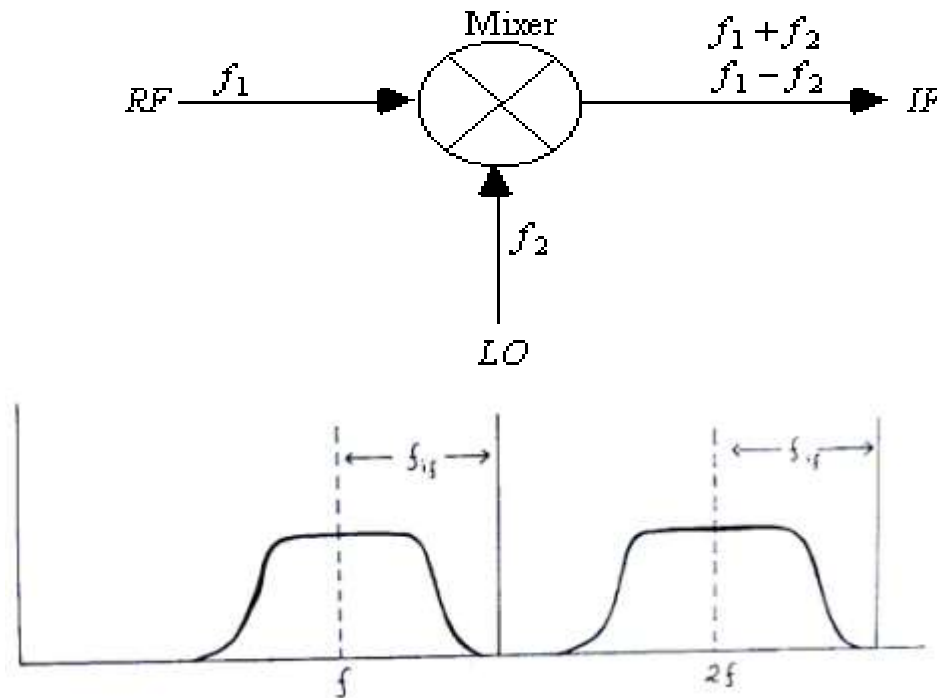

Fig 1. Mixerspectrum

Noise performance and rejection of out-of-band interferers are both critical to the receiver system because they both limit the receiver system's sensitivity. Linearity is important to transmitter performance, where the user wants an error-free output signal. Gain, NF, and non-linearity are the most important parameters in mixer design.

A single balanced mixer and a star mixer use two and quad anti-parallel diodes that provide inherent rejection of the input signal at the output due to their balanced amplitude and anti-phase properties. However, these two mixers require balun to feed LO or RF signal, and the balun is the key component in mixer design.



A large signal LO and a small signal RF combine at the anode of the diode. For an “ideal” single diode mixer, it is assumed that the LO is significantly stronger than the RF such that only the LO has the ability to affect the transconductance of the diode. Devices that possess such instantaneous transconductance switching are called ideal commutators and yield the theoretically optimal diode mixer performance.

The “mixing” process takes place due to the switching response of the diode I-V curve to the strong LO signal. As the diode is forced open and closed by the LO, the small signal RF is “chopped”. When we analyze the Fourier components of the output signal from a commutating (or switching) mixer diode. Thus, in the ideal case of a perfectly switching commutator, only odd harmonics of the LO are allowed to mix with the fundamental RF tone.

Unfortunately, the transfer function of the ideal commutator can never be achieved in the real world. Moreover, the RF will modulate the diode transconductance to some extent—even if the RF is very small. The combination of realistic diode I-V characteristics and transconductance modulation by the RF signal causes additional mixing products. Thus real diodes produce all possible harmonic mixing components.

Balanced mixers have been used in commercial and military equipment since before WWII. They have three advantages over single ended mixers:

- (i) a LO coupler or diplexer is not required ahead of the mixer,
- (ii) the required LO power is substantially less than that of a single-ended mixer with an LO coupler.
- (iii) sideband noise from the LO is suppressed.

LO power is usually coupled into a single ended mixer using a directional coupler or beam splitter. If the signal loss through the LO coupler is to be kept small, the LO loss must be substantial, typically 15-20 dB and most of the LO power is wasted. The balanced mixer has a separate LO port with efficient coupling so the required LO power is reduced by 12-17 dB relative to the simple single-ended mixer with LO coupler. In a single ended mixer, noise from the LO source in the signal and image bands is coupled into the mixer and converted to the IF. Depending on the nature of the LO source, its (sideband) noise temperature may be room temperature or higher. If the LO source has an effective noise temperature of 300 K at the sideband frequencies, then with a 15-20 dB beam splitter it will contribute 10-3 K in each sideband at the input of the mixer, which may be comparable with the intrinsic noise temperature of the receiver itself. With some LO sources it has been observed that considerably higher excess sideband noise — as much as 50 K of sideband noise at the input of the mixer with some frequency multipliers in the 200-300 GHz range. In a balanced mixer, sideband noise is suppressed by an amount depending on the phase and amplitude balance through the mixer. Balanced mixers require the relative phasing of the signal and LO at the two component mixers to differ by 180. This can be achieved either using a 180_ hybrid (transformer or magic-T) or a 90_ hybrid (3-dB directional coupler). The LO noise rejection of a balanced mixer depends on accuracy of the amplitude and phase.

Fig. 2 shows the effects of amplitude and phase imbalance in a balanced mixer. It is seen that the rejection is quite insensitive to asymmetries in the mixer — even with 2 dB amplitude imbalance.

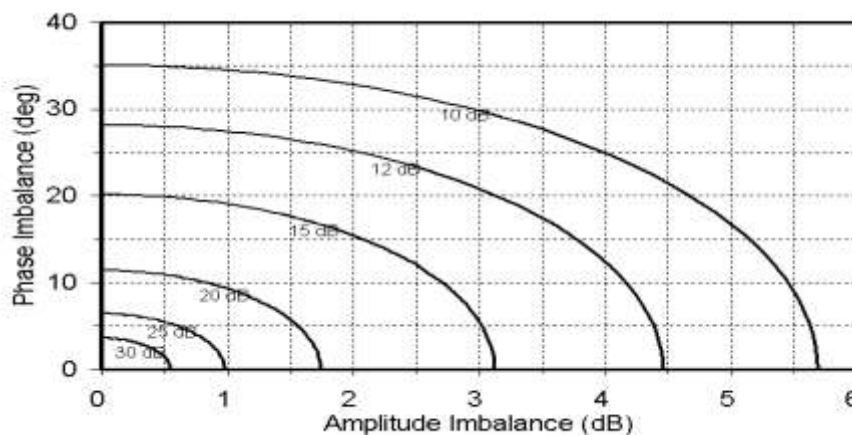

Fig 2. LO noise rejection of a balanced mixer as a function of amplitude and phase imbalance.



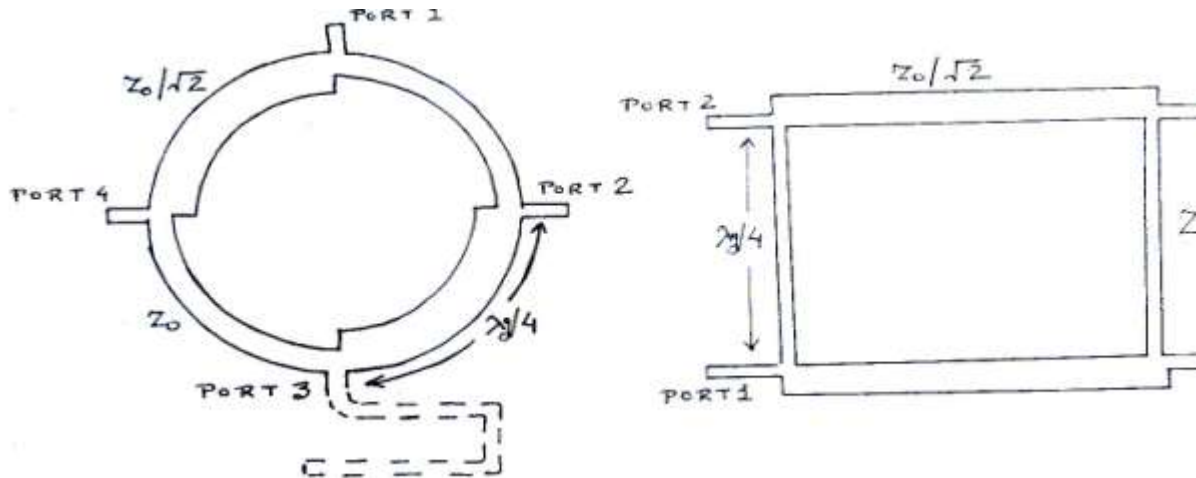

Fig 3. Microstrip implementation hybrid ring/Rat race circuit

An alternative way to obtain efficient LO coupling and rejection of LO sideband noise is to use a single-ended mixer preceded by a tuned diplexer — often a quasi-optical Martin-Puplett interferometer is used at millimeter and submillimeter wavelengths. This has the advantage of using a simpler mixer but requires a mechanically tunable diplexer if the receiver is to operate at different frequencies. Furthermore, with the Martin-Puplett type of diplexer, the bandwidth over which good LO noise rejection (> 10 dB) and low signal loss (< 0.4 dB) are obtained is restricted to $\sim 40\%$ of the IF center frequency. By comparison, a balanced mixer based on a broadband RF quadrature hybrid requires no tuning and should be useable with a multi-octave IF, such as the 4-12 GHz IF currently planned for the ALMA radio telescope.

In a double-balanced mixer, which utilizes a *diode ring* to achieve frequency conversion of the RF input signal. The mixer's diodes are being constantly switched *on* and *off* within the ring by the high-powered LO stage, while the RF signal is alternately sent through the diodes, mixing the two signals in a nonlinear manner, producing the IF output frequency. DBMs commonly function up to 8 GHz & beyond by using *hot-carrier (Schottky)* diodes, which possess low-noise and high conversion efficiency.

DBMs made of lumped components and placed on the wireless devices' PC board as a discrete circuit are seldom utilized today. Instead, double-balanced mixers are available in a module, with the diodes and transformers already balanced and placed within a surface-mount package.

Lower performing passive mixers that are not double balanced are available that employ either a single diode or double diodes. Unlike DBMs, they are cheap, require few components, and are relatively easy to design. There are several types of passive mixer designs available, depending on cost and performance levels required. A diode, *single-ended* mixer circuit is only found in very low-cost circuits, with the isolation between ports being supplied by bandpass and lowpass filters that are separated in frequency. Some of these single-ended mixer can also take advantage of a somewhat lower level of LO power needed to drive the singlediode mixing element, as compared to the often times higher drive levels required of a high-performance DBM stage. The single-ended mixer, however, has a relatively narrow bandwidth, poor port-to-port isolation, a low intercept point, and inferior intermodulation distortion suppression.

If we would like to increase the specifications and overall quality of this device, we will need to increase the number of diodes. This will permit a higher amplitude LO drive level input, which automatically forces an increase in the mixer's P1dB compression point. (The P1dB is normally specified at about 10 dB below the LO for all diode mixers. So, the higher the LO drive that can be inserted into a mixer, the higher the P1dB.) As we are demanding a more powerful LO for increased mixer performance, this will unfortunately not only cost more, but also radiate a higher level of EMI.

Single-balanced mixers, are comprised of two matching diodes, a balun, and generally two filters. The balun converts the unbalanced LO output to a balanced mixer input, matches the diodes to the port's impedance, helps in port-to-port isolation, and balances the diodes. The filters, one at each of the RF and IF ports, are to improve mixer isolation. This particular mixer type will balance out (cancel) and filter the LO power, preventing excessive LO feedthrough at the RF and IF ports. In fact, *single-balanced* mixers are superior to single-ended mixers in this LO-to-IF and LO-to-RF isolation, as well as in their wider bandwidth



operation. Furthermore, intermodulation distortion suppression is increased over the single-ended type. This is because any distortion products that are made up of even harmonics will be suppressed by the balanced-circuit action and, since twice as many diodes are typically used with this circuit, along with higher LO power, the same RF amplitude levels that are inserted into the single-balanced mixer's input will create less IMDs to be generated in the first place. As compared to a single-ended mixer, the negative attributes of a single-balanced mixer would be that the LO power must often be somewhat higher (which necessitates a more expensive and power hungry oscillator), and the part's count is increased (since a perfectly balanced balun and one more matched diode must be used).

Single-balanced mixers are so named due to their single-balanced balun, while double-balanced mixers are so named for the same reason; they employ two baluns. To any significant extent, quality double-balanced mixers will output only IMD products that are constructed of both odd RF and odd LO harmonics. This action decreases the DBM's total output of mixer products to a quarter of the amount generated within any simple mixer. However, mixer products are suppressed to varying levels, strongly dependent on the quality of the diode match and the accuracy of the balun balance. So, while a DBM often may require twice the LO power as a single-balanced mixer, as well as double the number of internal-balanced diodes and baluns, a DBM will have much better IMD suppression, a wider bandwidth, and a higher intercept point. *Triple-balanced mixers* (TBM, or DDM for *double double-balanced mixers*) have baluns located at all three ports, along with two complete diode rings. They have increased intercept points for decreased mixer product generation and two-tone intermodulation distortion levels, as well as better port-to-port isolation and a wider possible IF bandwidth output. However, TBMs need higher LO power, another matched diode ring, and one more balanced balun above that demanded by the DBM type. The price will be higher.

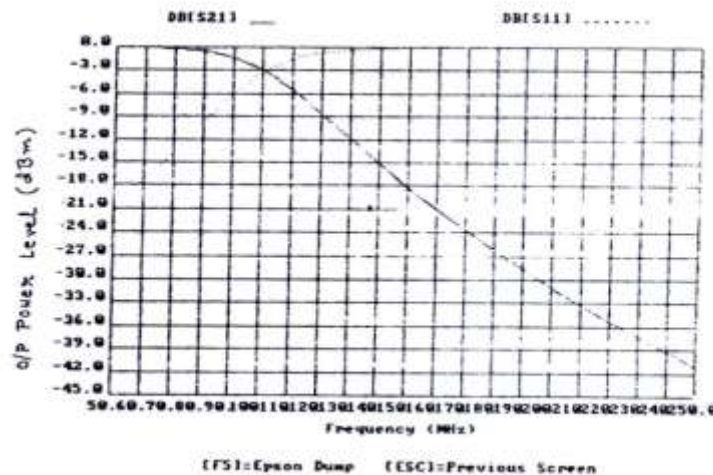

Fig 4. Simulated performance of Low pass circuit

Distributed Diode Single-Balanced Narrowband Hybrid Mixer for Microwave Frequencies

This mixer structure will have decent dynamic range, and requires approximately 8 to 10-dBm LO power, with satisfactory RF/LO-to-IF and LO-to-RF isolation for most applications. It enjoys very good IMD performance, with fair cancellation of even harmonic signals. However, the IF must be no higher in frequency than 50 MHz or so, since the difference between the LO and RF frequencies must be relatively small due to the mixer's resonant distributed design, which has to be able to effectively react to *both* the RF and the LO frequencies.

For maximum LO rejection, design each microstrip section for the LO's output frequency, or for midway between the LO and RF frequency values. The mixer's conversion loss will be approximately -6 dBm. The undesired mixer product frequency generation, and its suppression, is important in the entire heterodyning process. Output mixer products are formed by the mixing in the nonlinear diode elements of the incoming single-tone RF (and its own resultant harmonics), with the single-tone LO (and its resultant harmonics). This creates high-order distortion products that are higher and lower in frequency than the desired product, with this desired product normally being the difference frequency of the LO and RF in a receiver, or the sum of the LO and IF in a transmitter. Two-tone intermodulation products are created when two tones (f_1 and f_2) are placed at the RF input port of the receiver's mixer and, when mixed with each other and the LO, give birth to high-order in-band spurious responses at the IF output port of the mixer. While keeping in mind that the higher the possible LO oscillator power, the lower the distortion products.



Microwave Circular Rat Race Single-Balanced Diode Mixer

Very similar to the above mixer, this low-cost, distributed microwave diode mixer, when used with Schottky diodes, is an excellent choice for very high frequencies. It requires an 8-dBm LO drive level, has decent intermodulation performance, good RF/ LO-to-IF and LO-to-RF port isolation and, as with all diode mixers, will have a conversion loss (in this case, -6 dB). The IF must be no higher in frequency than 50 MHz or so, since the difference between the LO and RF frequencies must be relatively small due to the mixer's resonant distributed design; which has to be able to effectively react to *both* the RF and the LO frequencies. A broadband diode ring mixer that can be operated in fundamental and harmonic mixing modes. The mixer is double balanced when operated with external LO and IF baluns.

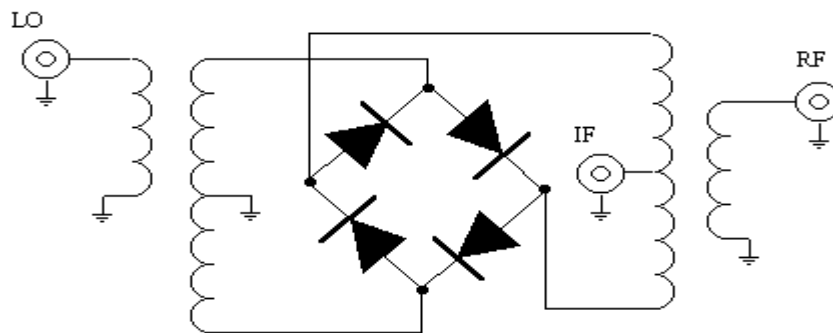

Fig 5. Diode ring double-balanced mixer

Design

In the present work, a balanced mixer is designed and developed at 1 GHz using microstrip line. Here, 1.0 GHz signal is converted to 100 MHz IF signal using 900 MHz local oscillator. The balanced mixer circuit consists of 3 dB branch line coupler and a low pass filter for IF section. Here a circular form of branch line coupler has been designed. A maximally flat Butterworth filter is used in this work. For proper function of the balanced mixer additional circuitry on the printed circuit board at the input port of LO has been used. The required design dimension using microstrip line has been calculated using synthesis subroutine. The CAD has been developed to design the 3 dB branch line coupler having input parameters as i) Frequency of operation, ii) dielectric constant, iii) height of substrate, iv) Thickness of Cu strip, v) characteristic impedance. The output parameters are i) width of stripline, ii) effective dielectric constant, iii) Guide wavelength. The layout using equivalent length of the microstrip line are generated. The hardware is implemented on a printed circuit board made of a GR10 substrate having dielectric constant 4.8 & thickness 1.6 mm.

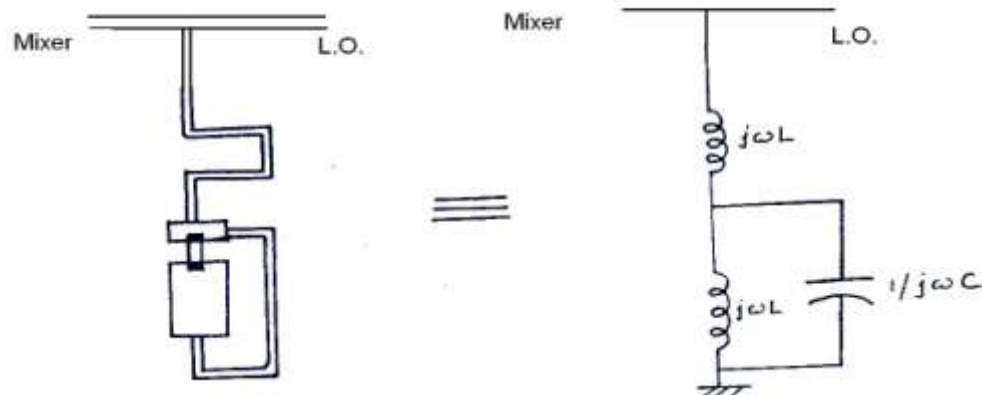

Fig 6. Layout of the low pass filter in distributed circuit



Measurement

The completed PCB is mounted on a rectangular brass plate and whole assembly is measured using a spectrum analyzer. The frequency response of the balanced mixer has been measured by spectrum analyser and two signal generators. Experimental results shows an output power of -39 dBm for an input power of -30 dBm. Since a 3 dB branch line coupler is used the output power should be 3 dB lower than the input power. The 6 dB additional loss is due to manufacturing tolerances and step discontinuities. The linearity of the designed mixer is also verified from the measurement results where the output power level changed equally with input power level upto 0 dBm. The unique characteristics of the balanced mixer can be implemented in practical applications like their high speed switching, square law characteristic, and low noise, provide a near ideal component for a variety of applications in modern communications and navigation systems.

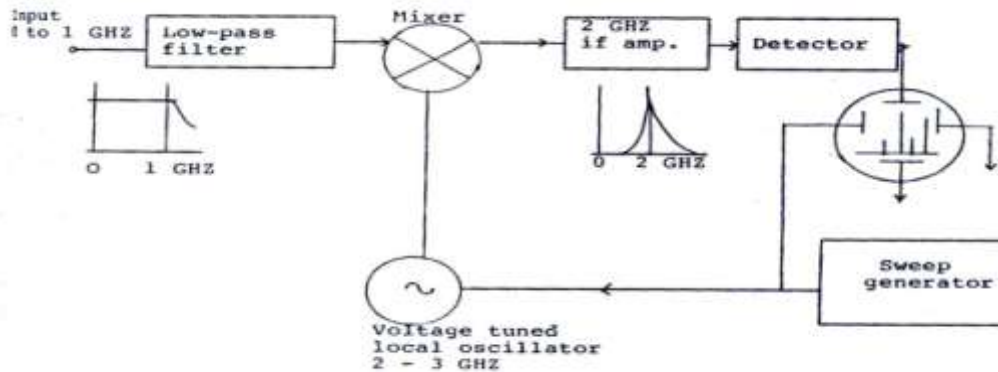

Fig 7. Measurement set up of the balanced mixer

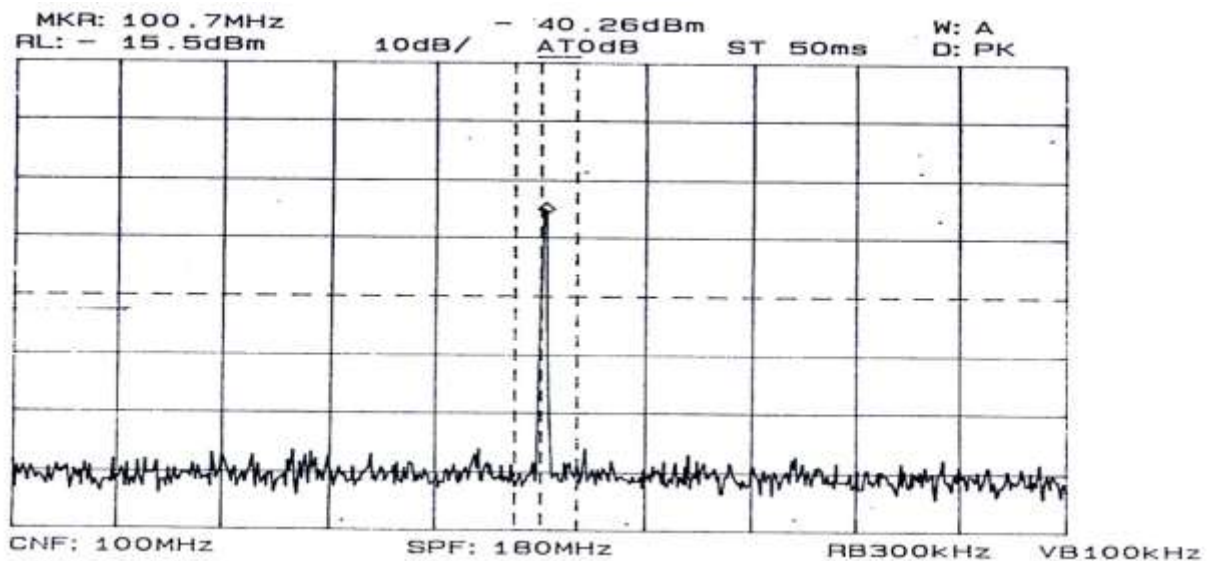

Fig 8. Output spectrum of the measured performance of the mixer.

