

Static Structural and Steady State Thermal Analysis of Piston Using ANSYS

Raghuveer Singh¹, Bharat Bhushan²

¹PG Scholar, Department of Mechanical Engineering, MITM Jevra, hisar (Hry.), India

²Assistant Professor, Department of Mechanical Engineering, MITM Jevra, hisar (Hry.), India

ABSTRACT

Piston is one of the most important components in internal combustion engine which reciprocates within the cylinder and is known as a 'heart' of an automobile engine. The main function of the piston of an internal combustion engine is to convert heat and pressure energy liberated by fuel combustion into mechanical work and transfer to the crank shaft through connecting rod. To improve the efficiency of the engine there is a need to study about the piston. In the project we used Finite Element Analysis method to optimize the piston design. In the work design of piston is made by using CATIA V5 design software and static structural analysis is carried out in ANSYS workbench software by optimize the material such as composite on the piston and the stress and deformation was calculated. The Finite Element Analysis results are significant to improve the component design at the early developing stage. The main objective of the work is to reduce the stresses and deformation of the piston without affecting the performance.

Keywords: ANSYS, Piston, CATIA V5, FEA.

I. INTRODUCTION

1.1 Introduction

The Piston is a 'heart' of an automobile engine. Piston is one of the most important components in I.C. engine which reciprocates within the cylinder. The main function of the piston of an internal combustion engine is to transfer force from expanding gas in the cylinder to the crank shaft through connecting rod [1].

Following are the main parts of piston

- 1) Piston Head or crown: It is flat, convex or concave depending on design of combustion chamber. It withstands pressure of gas in the cylinder.
- 2) Piston rings: It is used to seal the cylinder in order to prevent leakage of gas past the piston.
- 3) Skirt: It acts as bearing for the side thrust of connecting rod on the walls of cylinder.
- 4) Piston pin: It is also called gudgeon pin or wrist pin. It is used to connect the piston to the connecting rod. [2].

1.2 Functions

The functions which a piston is called to perform in an IC engine are;

- To form a seal so that the high strain gases within the combustion chamber do not get away into the crankcase.
- To serve as a consultant and a bearing for small end of the connecting rod. Aside from its ability to perform the above functions efficaciously the pistons need to have some other fascinating characteristics.
- The design will have to be such that the seizure does not occur.
- It must offer adequate resistance to corrosion because of some other products of combustion.

- It must have the shortest viable length as a way to cut down overall engine measurement.
- It must be lighter in weight in order that inertia forces created via its reciprocating motion are minimal.
- Its fabric will have to have a high thermal conductivity for effective warmth switch in order that bigger compression ratios may be used without prevalence of detonation. [1]

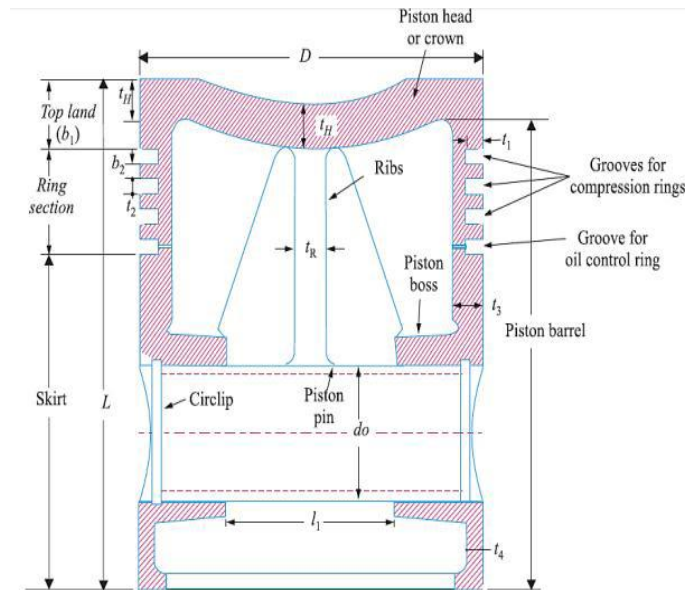

Figure 1: Piston Nomenclature

II. LITERATURE REVIEW

D. K. Sonar et al. [3] performed analysis of stress and design of piston head using CATIA & ANSYS. In this work a piston was designed using CATIA V5R20 software. Complete design was imported to ANSYS 14.5 software then analysis was performed. Aluminium alloy had been selected for structural and thermal analysis of piston. An analysis of thermal stress and damages due to application of pressure was presented and analyzed in this work. It was concluded that thermal stress was higher than mechanically induced stress hence it could be concluded that the piston would fail due to the thermal load rather than the mechanical load and hence during optimization design, this could be put into consideration to ensure that thermal load is reduced. It could also be deduced that individually, thermal and mechanical stress proportions have a direct influence on the coupled thermal-mechanical stress hence during design each load could be considered and reduced independently.

G. Sivaprasad et al. [4] performed the design and analysis of piston of internal combustion engine on different materials using CAE tool ANSYS. The objective of the paper was to analyze the I.C engine piston with the different materials Al alloy 4032, AISI4340 Alloy Steel & Titanium Ti-6Al-4V. The analysis completed on the different parameters (temperature, stress, deformation) of piston. It concluded that the maximum stress intensity was on the bottom surface of the piston crown in all the materials, but stress intensity was close to the yield strength of Al alloy piston. Maximum temperature was found at the centre of the top surface of the piston crown. This was equal for all materials. Depending on the thermal conductivity of the materials, heat transfer rate was found maximum in Al alloy piston.

K. S. Mahajan et al. [5] performed structural and thermal analysis of piston and in this work thermal analysis was carried out on uncoated and ceramic coated piston to verify the temperature changes at the ceramic coated regions using Hypermesh and Ansys. The study of thermal stresses generated due to temperature differences at different materials junctions used in coating was analyzed. It has been observed that the Thermal Stress Distribution was a function of coating thickness. With increase in thickness, the maximum temperature was increased on piston crown and the von-Mises stress was decreased with the increase in the coating thickness on the surface of the piston.

M. B. Shinde et al. [2] designed and analyzed Design Analysis of Piston for Four Stroke Single Cylinder Engine Using ANSYS. The aim of the project outlined in the paper was to make piston model using solid modeling software Creo / Pro 5.0. It has been decided to mesh the geometry analyze using ANSYS. For the analysis of piston input conditions and process of analysis, a lot of literature survey has been done. High combustion gas pressures would act as a mechanical loads and causes major stresses in the critical region of the piston. Detailed static structural analysis was

carried out for various loading conditions like maximum gas pressure load. Comparative study was done to select best material. It has been concluded that stress occurred by using Al-GHS1300 material was lower than the permissible stress value, so that Al-GHS1300 was best material for piston.

III. METHODOLOGY

Pre-Processing- The first step in Pre-Processing is to prepare a CAD model of piston. The model of piston is designed in CATIA V5 software and saved in iges format. The model of piston is then imported in SolidWorks software and saved in Parasolid (x_t) format file for no data loss. This Parasolid file of piston is then imported in ANSYS workbench. In the present work, material of piston is replaced by Aluminum Flyash Alumina Composite. The deformation and stress contours have find out using ANSYS workbench. The results obtained are compared with available results in literature survey. The figure 2 shows the drawing of piston.

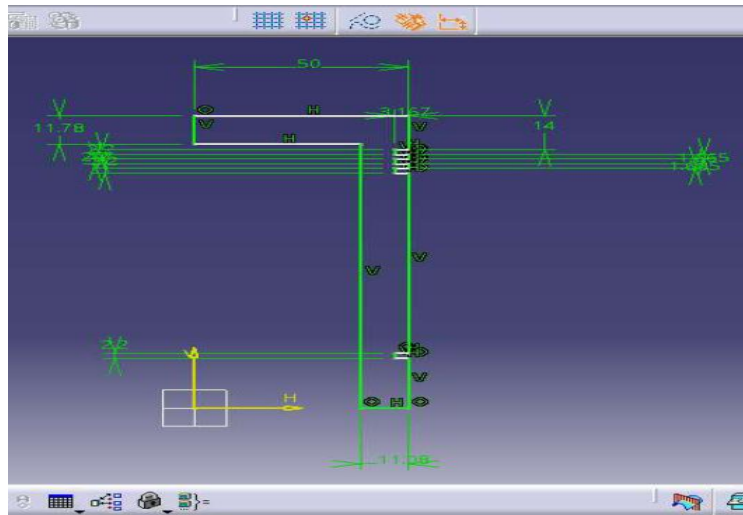

Figure 2 Piston Drawing

The Figures 3 and Figure 4 show the CAD model of piston in CATIA V5 Software and ANSYS workbench respectively.

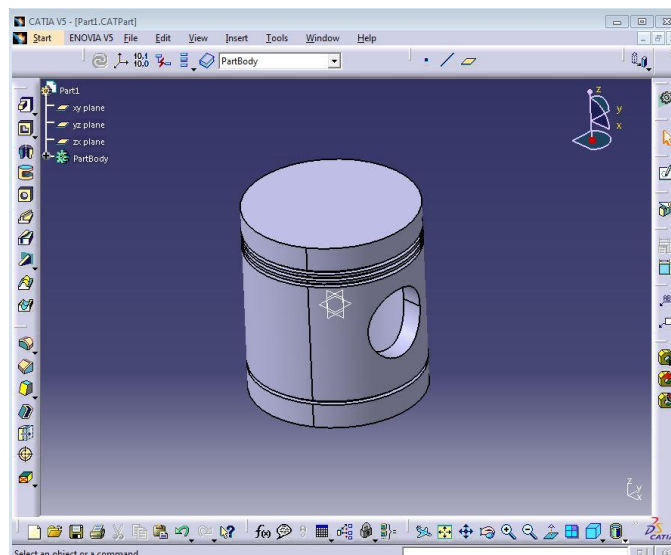

Figure 3 CAD model of Piston in CATIA V5

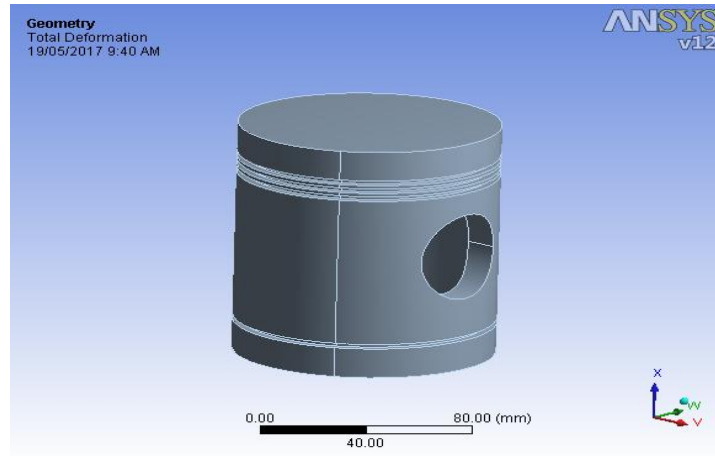

Figure 4 CAD model of Piston in ANSYS

Material Properties

The materials behaviour characteristics related to piston performance are first determined. The effect of component processing on these characteristics is then documented followed by a demonstration of the application of these concepts to component fatigue life of particulars concern in fatigue problems is the tendency for material properties to change as a result of cyclic deformation. The material used in this work is Aluminum Flyash Alumina Composite. Table 1 shows the mechanical property of Aluminum Flyash Alumina Composite [6].

Table 1 Mechanical Properties

Material	Aluminum Flyash Alumina Composite
Density	2.7 g/cc
Young's Modulus	68.9 GPa
Poisson's Ratio	0.33
Ultimate Tensile strength	330 MPa
Ultimate Yield strength	276 MPa

Mesh generation

Finite Element mesh is generated using parabolic tetrahedral elements. The Von-Mises stress is checked for convergence. An automatic method is used to generate the mesh in the present work. Figure 5 shows the meshed model of piston in ANSYS workbench.

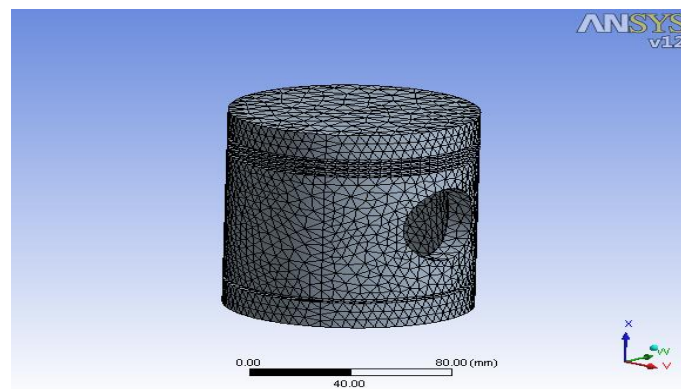

Figure 5 Meshed model of Piston in ANSYS workbench

Boundary Conditions

After completion of the Finite Element Model, boundary condition and loads are applied. User can define constraints and loads in various ways. This helps the user to keep track of load cases. The boundary condition is the collection of different forces, supports, constraints and any other condition required for complete analysis. Applying boundary condition is one of the most typical processes of analysis. A special care is required while assigning loads and constraints to the elements. Boundary condition of the piston involves the pressure and frictionless support. Loading conditions involves applying a pressure of 5Mpa at the top of piston head. The model under defined boundary conditions is shown in Figure 6 and Figure 7 [7].

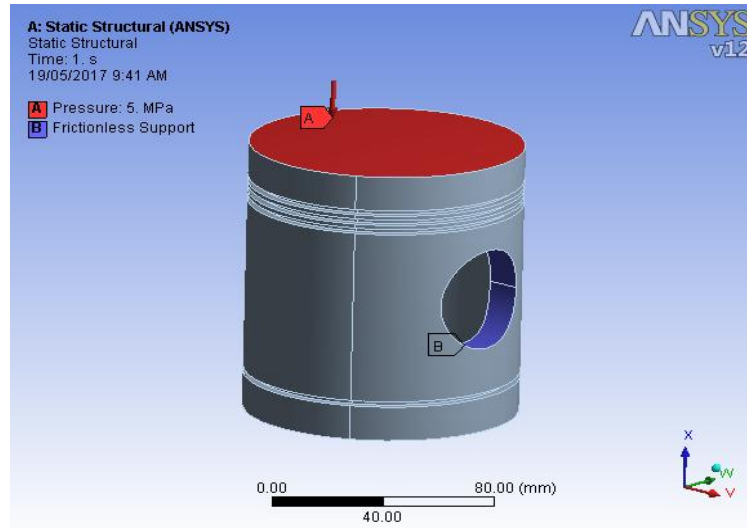

Figure 6 Applied Static constraints on Piston

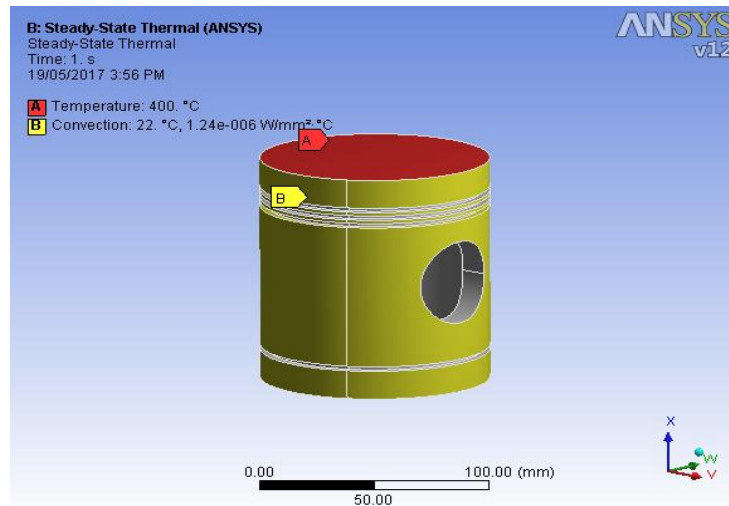

Figure 7 Applied Thermal constraints on Piston

IV. STATIC STRUCTURAL ANALYSIS

Static structural analysis is done in ANSYS workbench to find out the equivalent von-mises stress and total deformation. The maximum von-mises stress and maximum deformation is shown in Figures 8 and Figure 9.

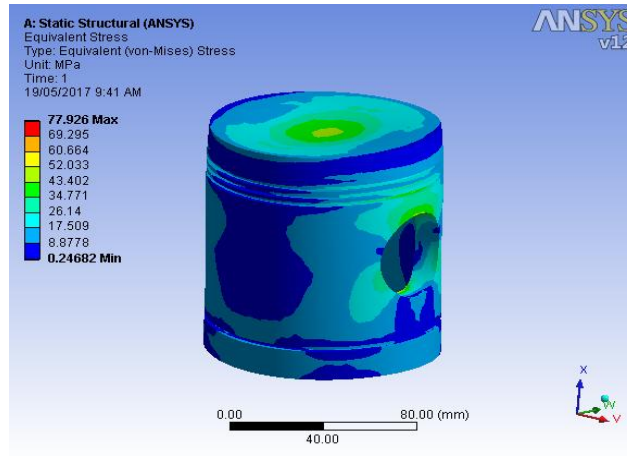

Figure 8 Equivalent (von-mises) stress

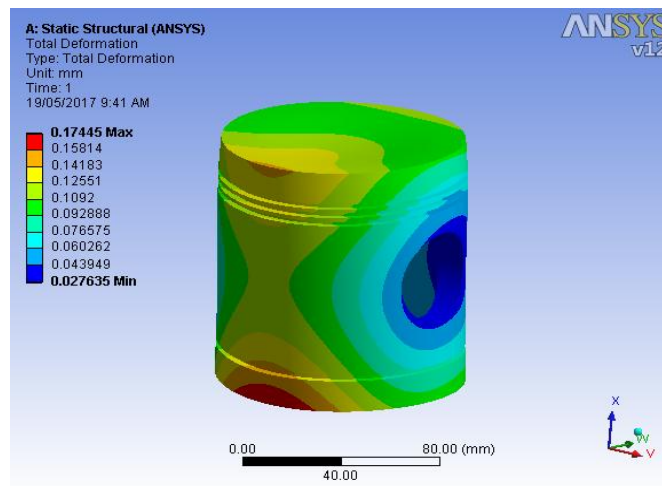

Figure 9 Total Deformation

V. STEADY STATE THERMAL ANALYSIS

Figures 10-11 show the Temperature Distribution and Heat Flux in the Piston respectively for a Temperature of 400 °C.

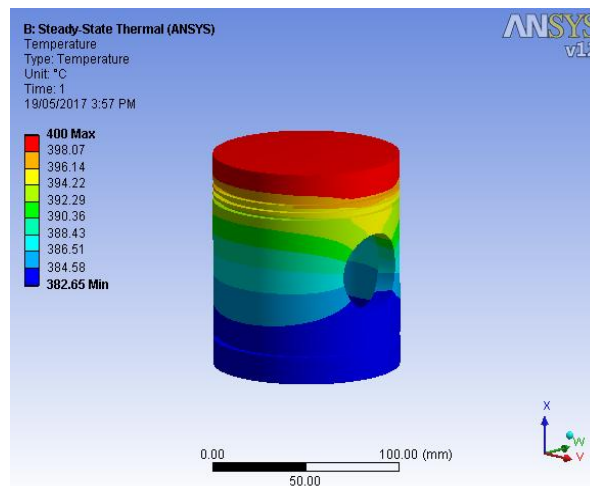

Figure 10 Temperature Distribution

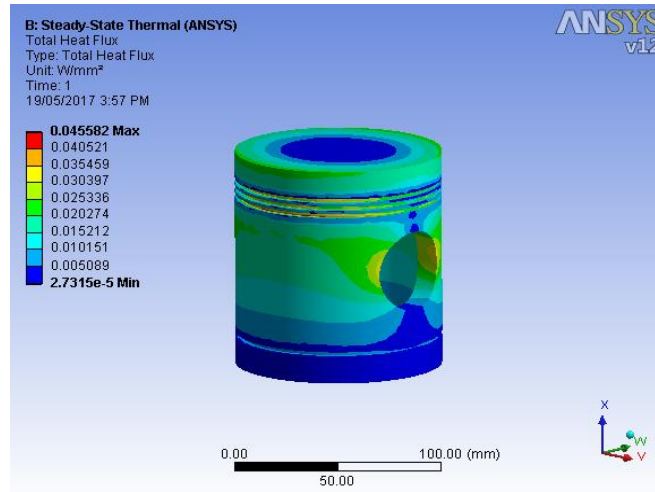

Figure 11 Total Heat Flux

The analysis results of Piston after optimization of the existing model are shown in table 2 and table 3.

Comparison of FEA results

Table 2 Static Structural FEA results of Piston

Sr. No.	Parameters	Existing Results	Modified Results
1.	Total Deformation in mm	0.7314	0.1744
2.	Equivalent (von-mises) stress in MPa	103.32	77.926

Table 3 Result for Temperature Analysis for Piston

Sr. No.	Parameters	Maximum Value	Minimum Value
1.	Temperature Distribution in °C	400 °C	385.65 °C
2.	Total Heat Flux in W/mm ²	0.04558	2.731 e-5

The FEA results are within the limit and are expectable. The values of total deformation, equivalent (von-mises) stress are much below the yield limit and present design is safe.

CONCLUSION

Finite Element Analysis of the piston has been done using ANSYS Workbench. From the results obtained from FE Analysis, many discussions have been made. The results obtained are well in agreement with the available existing results. The model presented here, is well safe and under permissible limit of stresses.

1. On the basis of the current work, it is concluded that the design parameters of the Piston with modification give sufficient improvement in the existing results.
2. The average piston temperature beneath the piston ring is about 65 °C.
3. It can be seen from the Fig. 6.1 that the maximum von mises stress is 77.926 MPa which is less than the ultimate stress.
4. The stress is found maximum near the hole and sharp edges.

REFERENCES

- [1] M. SreeDivya, Dr K.RajaGopal “Design And Material Optimization of the Piston By using PROE And ANSYS” ISSN: 2454-356X, IJASTEMS, Volume.2, Issue.9, Sept.2016.
- [2] Manisha B Shinde, Sakore T. V, Katkam V. D. “Design Analysis of Piston for Four Stroke Single Cylinder Engine Using ANSYS”, ISSN: 2347 – 5161, IJCET, Special Issue-6 (Oct 2016).
- [3] Dilip Kumar Sonar, Madhura Chattopadhyay “Theoretical Analysis of Stress and Design of Piston Head using CATIA & ANSYS”, ISSN: 2319 – 6726, IJESI, Volume 4, Issue 6, June 2015.
- [4] G.Siva Prasad, K.Dinesh Achari, E.Dileep Kumar Goud, M.Nagaraju, K.Srikanth “Design and Analysis of Piston of Internal Combustion Engine on Different Materials Using CAE Tool ANSYS” ISSN 2347-6710, IJRSET, Volume 5, Issue 4, April 2016.
- [5] K.S.Mahajan, S.H.Deshmukh “Structural and Thermal Analysis of Piston” ISSN: 2347 – 5161, IJCET, Special Issue 5, June 2016.
- [6] Sravani Pandi, P.V.Saiprasad “Design And Analysis Of Piston By Using Aluminum Alloys” ISSN 2320 – 3439, IJAEM, Volume 06, Issue 02, March 2017.
- [7] Amitanand B Suralikerimath, Yallanagouda I Ninganagoudar, C.M Veerendrakumar “Study on Design and Static Analysis of Piston Head” ISSN: 2321-7308, IJRET, Volume 5, Issue 10, Oct-2016.